



OWNERS HANDBOOK

# Contents

Using this Handbook .....	7
1. Before taking to the road.....	8
Explanation of Dashboard.....	9
Speedometer .....	9
Digital display within speedometer .....	9
Trip recorder reset button .....	9
Tachometer.....	9
Oil pressure gauge .....	9
Temperature gauge .....	9
Fuel gauge.....	10
Warning lights .....	10
Before you drive away .....	13
Pedal adjustment facility.....	13
Seats/seat belts/harness .....	13
Weather equipment assembly .....	14
Security .....	15
Keys/key numbers .....	15
Immobilisation.....	15
Vehicle battery disconnection.....	16
Ignition switch and steering lock.....	16
Steering lock .....	16
Starting the engine.....	17
Starting in cold climates.....	17
Warming up .....	17
Running-In.....	17
Catalytic converter .....	17
Filling up with fuel: .....	17
Starting the engine: .....	17
Driving the car:.....	17
Switching off: .....	17
Vehicle maintenance: .....	18
Gearbox .....	18
Selecting reverse gear.....	18
Precautions while driving.....	18
Sequential Gearbox Operation .....	18
Fuel .....	19
Fuel Filling .....	19
Filling difficulties.....	19
Braking System .....	19
Brake pads.....	19
Handbrake .....	19
2. Useful information .....	20
Technical data.....	21
Vehicle type .....	21
Construction.....	21
Braking system (All models excluding 170) .....	22
Braking system (170 only).....	22
Parking brake.....	22
Suspension – Standard / SV Chassis .....	22

Suspension – CSR Chassis .....	22
Steering mechanism .....	22
Road wheel nut torque .....	22
Electrical .....	22
Manual transmission.....	22
Recommended fluid specification .....	24
Track use .....	25
Enjoying track days and competing in your Caterham Seven. ....	25
Motorsport.....	25
Track days .....	25
3. Maintenance.....	27
Regular checks.....	34
Weekly checks.....	34
Emission control .....	34
Safety in the garage.....	34
Poisonous liquids.....	35
Used engine oil.....	35
Checking fluid levels .....	35
Engine oil levels.....	35
Engines with standard wet sump arrangement.....	35
Engines with dry sump tank - except CSR 200 / 260 .....	36
Engines with dry sump bell tank and swirl tower - CSR 200 / 260 Models only .....	36
Supercharger oil level checking and maintenance (For 620 R only) .....	36
Coolant check & top-up .....	36
Anti-freeze .....	36
Brake/clutch fluid check & top-up.....	37
Wipers & Washers .....	37
Windscreen washers .....	37
Washer jets.....	38
Wiper blades.....	38
Battery.....	38
Battery maintenance.....	38
Battery removal and replacement .....	38
Replacement battery .....	38
Battery disposal .....	39
Battery charging .....	39
Wheels & Tyres.....	39
Caring for your tyres .....	39
Tyre pressures.....	39
Tyre wear indicators .....	39
Valve caps .....	40
Punctured tyres .....	40
Replacement tyres.....	40
Changing a wheel and tyre assembly.....	40
Tools required.....	40
Positioning the jack.....	40
Removing and refitting the wheel and tyre assembly .....	40
Cleaning and car care.....	42
Washing your car.....	42
Removing tar spots.....	42
Body protection.....	42
Windscreen.....	42
Hood/Sidescreen .....	42

Mirrors .....	42
Wiper blades .....	42
Looking after the interior .....	42
Laying your vehicle up for long periods .....	43
Travelling abroad .....	43
4. In an emergency .....	44
Emergency starting .....	44
Emergency towing .....	44
Towing for recovery .....	44
Before being towed:.....	44
Fuses and relays.....	45
Fuses and relays - 170.....	45
Fuses and relays - 270/275/310.....	45
Fuses and relays - 360/420/620 .....	46
Fuses and relays - 485 .....	46
Renewing a fuse .....	46
Fuse colours .....	46
Parts & Accessories.....	47
Service parts & accessories .....	47
Bulb Replacement.....	47
Headlamps.....	47
Side lamp (front) .....	47
Indicators (front).....	47
Indicator repeaters (front) .....	47
Stop/tail and indicators (rear) .....	47
Rear fog light, reversing light.....	47
Number plate lamp .....	47
Torque Figures.....	48



# INTRODUCTION

## Congratulations on the ownership of your new Caterham Seven sports car.

Designed for racing and built for living, your Caterham Seven is competition-developed and capable of performance well in excess of your average supercar. Please take the time to read this manual, get well acquainted with the controls and understand the maintenance requirements of your car. This will help you appreciate its capabilities to the full whilst ensuring the appropriate upkeep of your Seven enabling you to derive maximum pleasure from ownership.

As a high performance car, it is likely that your Caterham Seven will be subjected to the stresses and strains of enthusiastic driving, particularly on the track. Therefore, it is essential that the maintenance programme of regular servicing and checks contained within this manual is adhered to. This will ensure that the vehicle is kept in the best possible condition and performing at its optimum. For all servicing, MOT's and other vehicle maintenance we recommend that you return your car to us here at Caterham where the work will be carried out by factory trained technicians. Alternatively, servicing and maintenance can be carried out by one of the Caterham approved service agents. Please refer to the Caterham website for up to date contact information [www.caterhamcars.com](http://www.caterhamcars.com).

## Using this Handbook

This handbook has been divided into sections, each dealing with the different aspects of owning and caring for your Caterham Seven. You will find lots of useful and worthwhile advice and tips to help you get to know and look after your new car.

- USING YOUR SEVEN
  - LOOKING AFTER YOUR SEVEN
  - TECHNICAL INFORMATION
  - SERVICE SCHEDULES AND RECORDS
- 
- **'Before taking to the road'** – Includes controls, pedal adjustment, seat adjustment, weather equipment fitting and storage, security and other information that you should know before you drive your new car.
  - **'Useful information'** – This section is where you will find all the technical data on your Caterham Seven.
  - **'Maintenance'** – Detailed here are all the regular checks you will need to carry out to ensure you continue to get the best from your Caterham Seven.
  - **'In an emergency'** – Should an emergency arise then here you will find advice on what you can do, including jump starting, checking the fuses and changing a bulb.
  - **'Servicing'** – This section provides vehicle service information including service schedules. In addition, you will find pages that can be used to keep a record of when and where a service took place plus an additional section for any future modifications or upgrades to your vehicle.

## WARNING!

*Safety warnings are included in this handbook. These indicate either a procedure which must be followed precisely, or information that should be considered with great care in order to avoid the possibility of personal injury or serious damage to the vehicle.*

## Before taking to the road

### Dashboard layout for models with standard instruments

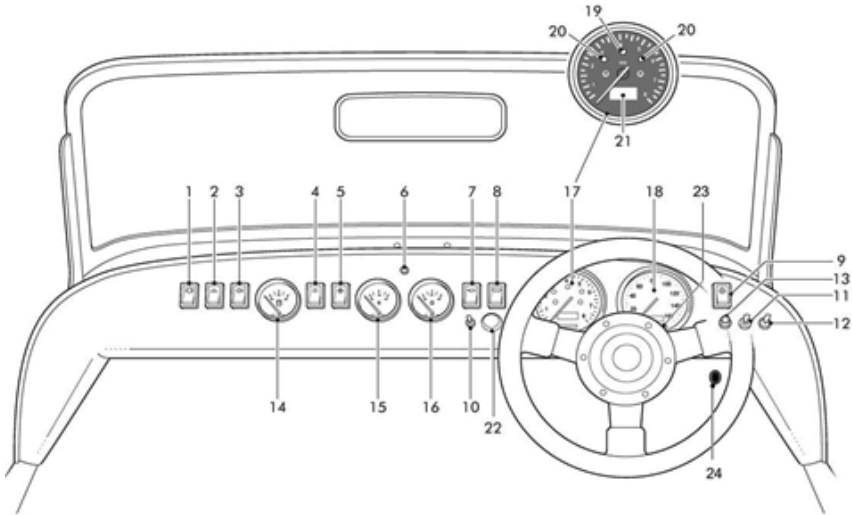

Standard 5 Speed.



Standard 6 Speed.

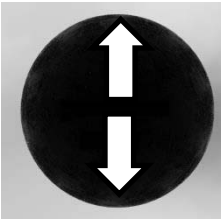

Sequential 6 Speed.

**Note for 6 speed sequential: Arrows are for illustration only:**

Upwards arrow = Down shift 1 gear

Downwards arrow = Up shift 1 gear

See page 18 for further details.

#### Key:

- |   |  |
|---|--|
| 1. Brake fail indicator (excl. 170/270/275/280/310) | 13. Horn   |
| 2. Hazard warning light switch                      | 14. Fuel gauge   |
| 3. Rear fog light switch                            | 15. Temperature gauge  |
| 4. Heated windscreen switch                         | 16. Oil Pressure gauge                                       |
| 5. Heater fan switch                                | 17. Tachometer   |
| 6. Immobiliser warning light                        | 18. Speedometer  |
| 7. Windscreen washers switch                        | 19. main beam warning light                                  |
| 8. Windscreen wipers switch                         | 20. Indicator warning light                                  |
| 9. Side lights/head lights switch                   | 21. Ignition warning light, MIL & brake system warning light |
| 10. Indicators switch                               | 22. Push starter button                                      |
| 11. Main beam switch                                | 23. Trip reset button  |
| 12. Headlamp flasher switch                         | 24. Heater valve control                                     |

## Explanation of Dashboard

Brake fail indicator	Single position spring loaded switch, illuminates to indicate low fluid level. Press to test bulb.
Hazard warning light	Single position switch activates all indicators.
Rear fog light	Single position switch activates rear fog lights when dipped headlights are illuminated. (spring-loaded switch for Seven 170 & 270/275/280/310, operates when ignition is on and main or dip beam headlamps are illuminated. The rear fog light will automatically switch off if the ignition or headlamps are switched off.)
Heated windscreen	Single position switch activates heating elements to demist front windscreen.
Heater fan	Two position switch provides low and high speed fan control.
Windscreen washers	Single position spring-loaded switch activates washer jets when depressed.
Windscreen wipers	Two position switch to provide low and high-speed continuous wipe.
Indicator switch	Three position switch Left-Off-Right (not self-cancelling)
Side/Head lights	Two position switch, first position side lights, second position dipped beam headlight.
Main beam	Two position switch for dip or main beam.
Headlamp flasher	Single position spring-loaded switch to flash headlights.
Heater valve control	This is located on the inside of engine compartment bulkhead, above the driver's knee. Pull towards driver to increase heat.
Starter push button	Single position spring-loaded push switch, press and hold to start engine
Horn push button	Single position spring-loaded push switch

### Speedometer

Indicates road speed in miles per hour and/or kilometres per hour.

### Digital display within speedometer

The display shows the following:

- Odometer reading (shows the total distance travelled by the car).
- Trip recorder (for recording individual journey distances). The word trip is also displayed.

### Trip recorder reset button

Whenever the ignition switch is turned on, the display shows the odometer reading. By pressing the trip recorder reset button briefly, the display will change to show the trip recorder reading (a further press of the button returns the display to the odometer reading). Press and hold the reset button to reset the display to zero.

### Tachometer

Indicates engine speed in revolutions per minute.

**NOTE:** An electronic limiter will prevent engine speed rising above a pre-determined factory set level.

### Oil pressure gauge

The needle indicates the oil pressure measured in bar. The needle will quickly rise when the engine is started. If the needle falls into the red mark during normal running the oil pressure is at a critical level and severe engine damage could result; switch off the engine immediately (safety permitting) and seek qualified assistance. (Engine pressure will fluctuate as engine revs change).

### WARNING!

*Never restart the engine or drive the car with the oil pressure gauge indicating red.*

### Temperature gauge

Indicates the temperature of the engine coolant. During normal operation, the needle will rise from the lower (cold) mark to the middle part of the gauge, where it will remain while the engine is operating at its normal temperature. In severe driving conditions, such as very hot weather or extended hill climbing, the needle may rise. If the needle rises to the red mark, the coolant is too hot and severe engine damage could result; stop the car as soon as safety permits and seek qualified assistance.



**Fuel gauge**

The needle indicates the fuel level. After refuelling, the gauge slowly rises to the new level once the ignition switch is turned on.

**WARNING!** NEVER allow the car to run out of fuel (the resultant misfire could destroy the catalytic converter).

**Warning lights****Battery charging – Red**

The light illuminates as a bulb check when the ignition switch is turned to position 'II' and extinguishes as soon as the engine is running. If it remains on, or illuminates whilst driving, a fault with the battery charging system is indicated. Seek qualified assistance from Caterham.

**Direction indicators – Green**

The indicator warning light flashes in time with the left or right direction indicator lights, whenever they are operated. If the warning light fails to illuminate or flashes very rapidly, this means that one of the indicator lights is not operating.

**Engine warning - Amber**

If this lamp illuminates with the engine running it indicates a malfunction within the engine control system. Each malfunction will have a specific code and description and can be read using an OBD generic scan tool. This should be carried out as soon as possible. If engine warning light persists, please seek qualified assistance from Caterham.

**Brake system – Red**

The light has dual function for 'low brake fluid' and 'hand brake applied'. The light illuminates as a bulb check when the ignition switch is turned to position 'II' and extinguishes soon after. The light will continue to illuminate for as long as the hand brake is applied. If it remains on when the hand brake is released, a fault with the brake fluid level is indicated. Seek qualified assistance from Caterham.

**Headlight main beam – Blue**

Illuminates when the headlights are switched to main beam.

**Immobiliser warning light - Red**

See section on [Immobilisation](#).

**Dashboard layout for Seven 480/485**

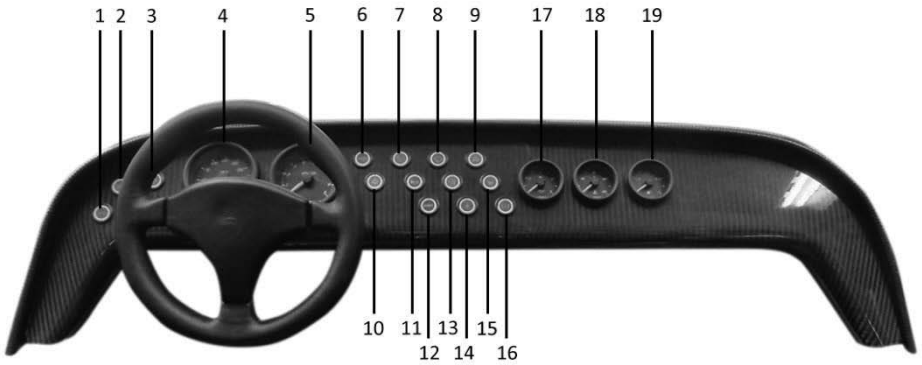

<b>Controls</b>	
1.	Dipped / Side Lights
2.	Main Beam switch
3.	Left indicator switch
4.	Speedometer
5.	Rev Counter
6.	Sport Mode switch
7.	Wiper switch
8.	Washer jet switch
9.	Hazard switch
10.	Right indicator switch
11.	Horn switch
12.	Start switch
13.	Fog light switch
14.	Fan control switch
15.	Heated screen switch
16.	Handbrake indicator
17.	Oil pressure gauge
18.	Temperature Gauge
19.	Fuel Gauge

*NOTE: For full windscreen option the wiring connection to dashboard buttons for heated screen, wipers etc are already connected.*

## Dashboard Layout for Seven 620

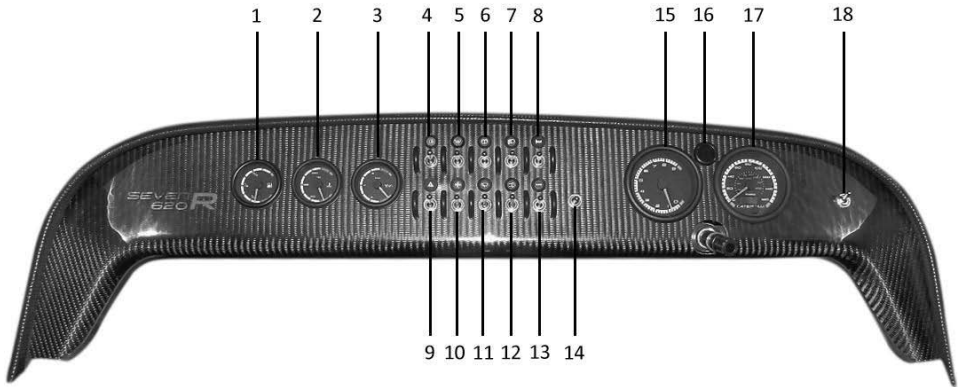

Note: 620 Dashboard with steering wheel removed.

Controls	
1.	Fuel gauge
2.	Temperature gauge
3.	Oil pressure gauge
4.	Fog light switch
5.	Heated Screen switch
6.	Screen washer switch
7.	Main Beam switch
8.	Horn Switch
9.	Hazard Switch
10.	Heater Fan Switch
11.	Wiper Switch
12.	Dipped beam / sidelights
13.	Start Switch
14.	Indicator Switch
15.	Rev Counter Display
16.	Gear indicator Display
17.	Speedometer
18.	Flasher Switch for Main

*NOTE: For full windscreen option the wiring connection to dashboard buttons for heated screen, wipers etc are already connected if specified.*

## Before you drive away

### Pedal adjustment facility

On some models the pedals may be adjusted to suit the driver. Please contact your Caterham dealer or local agent for details, (Note: not all cars have this facility).

### Seats/seat belts/harness

#### **Forward/backward adjustment**

Lift the seat adjustment lever up to release the catch enabling the seat to slide back or forward. Ensure the seat is locked in position before driving off.

It is often much easier to adjust the seat whilst sat in the vehicle.

#### **WARNING!**

*DO NOT adjust the seat while the car is in motion.*

#### **Head restraints**

Head restraints are designed to restrain rearward movement of the head in the event of an accident or sudden stop.

#### **WARNING!**

*Never drive the car with the head restraints removed.*

#### **Seat belt safety**

The seat belts supplied with your car are intended for use by adult sized occupants and must be used by one occupant ONLY. Seat belts are lifesaving equipment and are required by law to be worn at all times whilst in a vehicle. In a collision, unrestrained passengers can be thrown around inside, or possibly thrown out of the car, resulting in injury to themselves and to other occupants.

**ENSURE that the passenger is securely strapped in at all times.**

- ALWAYS adjust seat belts to eliminate any slack in the webbing. DO NOT slacken the webbing by pulling the belt away from the body – to be fully effective, the seat belt must remain in full contact with the body at all times.
- ALWAYS fit the lap strap across the pelvis (never across the abdomen), and ensure that the diagonal strap passes across the chest, without slipping off the shoulder, or pressing against the neck.

- DO NOT fit more than one person into a belt, or use a seat belt that is twisted or obstructed in any way that could impede its smooth operation.
- DO NOT wear seat belts over hard or fragile items in clothing, such as pens, keys, spectacles etc.
- DO NOT allow a baby or infant to be carried on the lap. The force of a crash can increase effective body weight by as much as 30 times, making it impossible to hold on to the child.
- DO NOT allow foreign matter to enter the seat belt buckles as this can render the buckles inoperative.
- Pregnant women should ask their doctor for advice about the safest way to wear seat belts.

#### **Caring for seat belts**

Regularly inspect the belt webbing for signs of fraying, cuts and wear, also paying particular attention to the condition of the fixing points and adjusters.

Care should be taken to avoid contamination of the webbing from the effects of polish, oil and chemicals ([see 'Cleaning & car care'](#)).

#### **Three tests for checking seat belts**

- 1) With the seat belt fastened, give the webbing near the buckle a quick upward pull – the buckle should remain securely locked!
- 2) With the seat belt unfastened, unreel the webbing to the limit of its travel. Check that unreeling is free from snatches and snags.
- 3) With the webbing half unreeled, hold the tongue plate and give it a quick forward pull – the mechanism must lock automatically and prevent any further unreeling!

#### **WARNING!**

*Always replace a seat belt assembly that has withstood the strain of a severe vehicle impact, or one where the webbing shows signs of fraying.*

#### **Harnesses**

A multi-point harness holds the driver firmly in the seat at all times (unlike a seatbelt which 'locks' on impact only). Aside from the increased safety benefit and being held more securely in extreme circumstances such as a track day driving, a harness will remove the tendency for the driver to brace themselves in corners using the steering wheel, with better control of the car as a result.

The lap strap is engaged first, ensuring that it is adjusted so that it sits across the lap at the lowest point. It should tighten enough that it requires effort to engage. Shoulder straps are then engaged into

the appropriate slot and tightened by pulling on the adjuster strap. A harness should feel tight when worn and not allow any movement of the torso. Although this feels restrictive at first, a driver will quickly get used to and ultimately prefer this feeling in a Seven.

To exit from the harness, the spring loaded buckle is rotated 90deg.

#### 4-point and 6-point harness

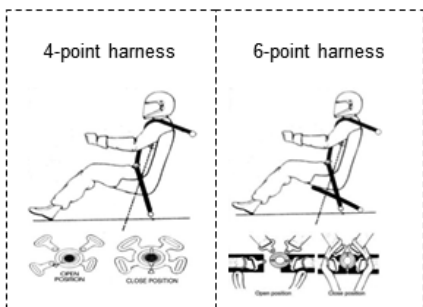

#### Harness adjustment

Slide the tail strap web through the metal three bar slide to set up the perfect strap length. The shoulder strap adjusters should sit on the breast bone, by doing this first you will ensure that the comfort pads are located in the correct position. Tighten the lap straps first making sure the release buckle is in a central position, final adjustment is taken up by pulling down on the shoulder straps.

#### WARNINGS!

*Always check your harness regularly for chaffing, stitch damage or hardware corrosion. Pay particular attention to areas that may not be visible such as under seat or cowlings.*

*Petrol, battery acid, bleach or similar solvent must not spill onto the webbing.*

*Always wear your harness as tight as comfort will allow but no tighter as loss of circulation may occur.*

*Always replaces a harness that has been involved in an accident or damage has taken place.*

**Never** make any changes to your system either by cutting and re-sewing webbing or by modifying the hardware.

## Weather equipment assembly

Erecting the hood is relatively straightforward if the correct procedure is followed. Therefore we recommend that the following sequence is adopted:-

- i) Erect the hoodsticks slacken the buckles to allow the front hoodsticks to collapse forwards over the roll bar.
- ii) Unfold the hood and popper it onto the windscreen first.
- iii) Stretch the rear of the hood over the back of the car and clip it over the poppers situated on the back panel starting at the outside and working into the centre.
- iv) Attach to the remaining poppers on the sides of the vehicle.
- v) From the inside of the car, tension the hood by pulling on the loose end of the straps re-tensioning the buckle (the buckle will automatically lock in position when released). The straps should be adjusted until the front hoodstick is in line with the hood seam. (See Fig 7).
- vi) The Velcro lined strips inside the hood should now capture the front hoodstick, which prevents the hood from ballooning at speed.
- vii) The tops of the sidescreens tuck under the flaps on the hood sides in order to make the hood watertight. At the rear, however, the sidescreens overlap the hood.

#### Tensioning the hood

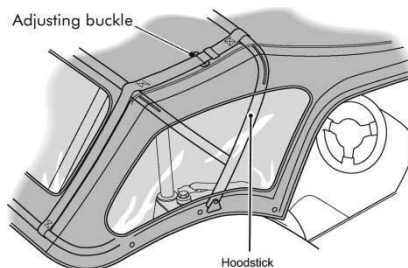

#### Removal and storage

To remove the hood slacken the buckles and remove in reverse to the above. (Vii to i)

It is important that the hood is folded correctly when removed in order to avoid unsightly creases and to prevent the clear plastic windows from being scratched or splitting. We suggest that it is always folded and then rolled as shown in Fig 7.

To help prevent damage, and free up storage space, a protective hood bag is available from Caterham.

**NOTE:** *Never store the hood when wet.*

### Hood folding procedure

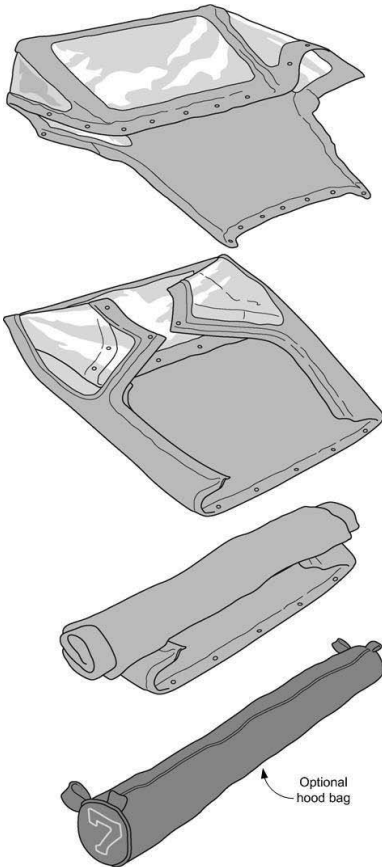

## Security

### Keys/key numbers

You have been supplied with 4 keys: 2 for the ignition and 2 for the fuel cap. The numbers for these can be found on a small tag attached to the key ring.

You will also have been supplied with 2 coded transponder tags.

### WARNING!

*Keep the key tag and spare key in a safe place – NOT IN THE CAR!*

If the key or tag is lost please contact Caterham to make arrangements for an additional set of keys and tags.

### Immobilisation

Most Caterhams are fitted with an immobiliser as standard.

### Disarming the system

Insert your ignition key with the transponder unit attached to the same key ring and the reader unit will automatically recognise the transponder and disarm your immobiliser. The LED state will change from fast flashing to off indicating the vehicle can be started.

### Arming the system

When the vehicle's ignition is switched off and the keys are removed from the ignition, the immobiliser will prepare to arm and the red LED will illuminate. During this period, the ignition can be switched back on, cancelling the arming and permitting the vehicle to be started as normal.

If after twenty seconds the ignition has not been turned on, then the immobiliser will automatically 'arm' and the red LED will flash. This 'auto-arming' sequence means that it is possible to leave your vehicle unprotected.

### WARNING!

*Your system will automatically re-arm within twenty seconds of disarming if you do not turn the ignition on.*

### Programming new transponder tags

If you require a new transponder tag for an additional user, or as a replacement through loss or damage, please contact Caterham.

Once you have received your new transponder tag, you will need to programme it. To do this you must have an existing transponder tag that already operates the system.

- 1) Disarm the system using an existing transponder tag attached to the ignition key.
- 2) Switch the ignition on and off twice and then turn the ignition back on, all within 7 seconds (the LED will flash rapidly).
- 3) The system will then recognise the transponder tag on the key ring and re-programme it.
- 4) The LED will flash once to indicate it recognises the transponder tag.
- 5) Remove the ignition key with the transponder tag attached.
- 6) Pass a new transponder tag close to the ignition barrel.
- 7) The LED will flash twice to indicate that the new transponder tag is in the memory.
- 8) Pass any additional transponder tag close to the ignition barrel.
- 9) For each transponder tag programmed into the system the LED will flash a number of times to indicate how many transponder tags are programmed into the system.
- 10) When you have finished, switch the ignition off and the immobiliser will exit the programming mode.

Each time you programme a new transponder tag into the system it will automatically erase all other transponder tags in the memory therefore all transponder tags required to operate the system must be programmed back in.

**NOTE:** For EU cars the transponder is in the key, if you require a new transponder as a replacement through loss or damage please contact your local dealer.

#### **Deleting lost transponder tags from the system memory**

If you lose one of your transponder tags, your vehicle is no longer totally secure, as anyone who finds your lost transponder tag could disarm your immobiliser. To prevent this from happening you are able to delete transponder tags from the system.

Because your immobiliser system will recognise up to five different transponder tags, you will have to re-programme all of your existing transponder tags every time you enter programming mode.

**NOTE:** The immobiliser is electronic immobiliser and derives its main power from your car battery. However, the consumption in the armed state is such that it should not adversely affect your car battery.

#### **WARNING!**

*The tags contain delicate electronic circuits and must be protected from impact and water damage, high temperatures and humidity, direct sunlight, effects of solvents, waxes and abrasive cleaners.*

#### **Vehicle battery disconnection**

If the car battery is disconnected for any reason the status of the security system prior to disconnection will be memorised and automatically reset when the battery is reconnected.

#### **Ignition switch and steering lock**

The ignition switch uses the following sequence of key positions to operate the steering lock, electrical circuits and starter motor:

##### **'O' – Steering locked**

With the key removed, the steering column will be locked and most electrical circuits are non-operational.

##### **'I' – Steering unlocked**

Turn the switch to position 'I' to unlock the steering.

##### **'II' – Electrical circuits on**

With the switch in position 'II' all electrical circuits are operational.

##### **'III' – Starter motor operates**

Turn the switch to position 'III' to operate the starter motor; release the key as soon as the engine starts (the key will automatically return to position 'II').

#### **Steering lock**

##### **To unlock the steering:**

Insert the key FULLY and turn the ignition switch to position 'I' – a small movement of the steering wheel may be necessary to disengage the lock.

##### **To lock the steering:**

With the ignition switch turned to position 'O', remove the key and turn the steering wheel until the lock engages.

**NOTE:** Cars fitted with a quick release steering wheel do not have a steering lock mechanism.

#### **WARNING!**

*Once the steering lock is engaged it is impossible to steer the car.*

*DO NOT remove the key, or turn the ignition switch to position 'O' while the car is in motion.*

## Starting the engine

### **WARNING!**

*Before starting the engine, ensure you are familiar with the procedures below. Catalytic converters are easily damaged through improper use, particularly if the wrong fuel is used or if an engine misfire occurs – before starting the engine you should be aware of the precautions detailed in the '[Catalytic converter](#)' section.*

*Never start or leave the engine running in an unventilated building – exhaust gases are poisonous and contain carbon monoxide which can cause unconsciousness and may even be fatal.*

- 1) Check that the handbrake is on and that the gear lever is in neutral.
- 2) Switch off all unnecessary electrical equipment.
- 3) Turn the ignition switch to position 'II' and release the key as soon as the engine has started.

**NOTE:** *For cars fitted with a push button start, turn the ignition switch to position 'II' and press the red push button and release the button as soon as the engine starts.*

### **WARNING!**

*DO NOT press the accelerator pedal while starting and DO NOT operate the starter for more than 15 seconds at a time. If the engine fails to start switch off, wait for at least 10 seconds before trying again.*

**NOTE:** *When the battery is in a low state of charge, depress the clutch before starting and hold it down until the engine is running.*

### **Starting in cold climates**

In freezing conditions, fully depress the clutch pedal while starting and hold it down until the engine is running. Note that engine cranking times will increase and that the battery charging light may take several seconds to extinguish.

### **Warming up**

In the interest of fuel economy, it is advisable to drive the car soon after starting, remembering that harsh acceleration or labouring the engine before the normal operating temperature has been reached can damage the engine.

## Running-In

The engine, gearbox, brakes and tyres need time to 'bed-in' and adjust to the demands of everyday motoring. During the first 500 miles (1,000 km) it is essential that you drive with consideration for the running-in process and heed the following advice:

- DO NOT allow the engine to exceed 4,000 rev/min in any gear.
- DO NOT operate at full throttle in any gear.
- DO NOT allow the engine to labour in any gear.
- AVOID heavy braking.

After the running-in distance has been completed, engine speeds may be gradually increased.

### **Catalytic converter**

The exhaust system on your car incorporates a catalytic converter, which converts poisonous exhaust emissions from the engine into environmentally less harmful gases, thereby reducing atmospheric pollution.

### **WARNING!**

*The catalytic converter can be easily damaged through improper use, particularly if the wrong fuel is used. For this reason, it is VERY IMPORTANT that you heed the following precautions:*

### **Filling up with fuel:**

Use ONLY fuel recommended for your Caterham model (see '[Technical Data](#)').

### **Starting the engine:**

#### **WARNING!**

DO NOT continue operating the starter if the engine fails to start after a few attempts (unburnt fuel may be drawn into the exhaust system, thereby damaging a catalyst) – seek qualified assistance. If a misfire is suspected when starting, DO NOT drive the car or attempt to clear the misfire by pressing the accelerator pedal. DO NOT attempt to push or tow start the car. Instead, turn the ignition switch off immediately and seek qualified assistance from Caterham.

### **Driving the car:**

Provided the engine has reached its normal operating temperature, if a misfire is suspected or the car lacks power while driving, it may be driven SLOWLY (at risk of catalyst damage) to Caterham for assistance.

Never allow the car to run out of fuel (the resultant misfire could destroy a catalyst).

An engine burning excessive oil (blue smoke from the exhaust), will progressively reduce catalyst efficiency.

Do not overload the engine.

### **Switching off:**

DO NOT switch off the engine whilst the car is in motion, with a forward or reverse drive gear selected.



### Vehicle maintenance:

Any engine misfire, loss of engine performance or engine run-on, could seriously damage the catalytic converter. For this reason, it is vital that unqualified persons do not tamper with the engine and that regular maintenance is carried out by Caterham, in accordance with the service interval plan included in this book.

### WARNING!

*DO NOT run the engine with a spark plug or lead removed, or use any device that requires an insert into a spark plug.*

*Exhaust temperatures can be extremely high; DO NOT park on ground where combustible materials, such as dry grass or leaves, could come in contact with the exhaust system – in dry weather a fire could result.*

*Cooling fans may operate after the engine is switched off. Keep clear of all fans while working in the engine compartment.*

*Before carrying out maintenance checks or working in the engine compartment, ALWAYS observe the safety precautions listed under 'Safety in the garage'.*

## Gearbox

The gear positions are indicated on the gear lever knob. Synchromesh engagement is provided on all forward gears and in the neutral position the gear lever is spring loaded to rest naturally between 3rd and 4th gears.

### Selecting reverse gear

Before selecting reverse gear, ENSURE THE CAR IS STATIONARY; then, fully depress the clutch pedal and pause briefly before moving the gear lever into position by pushing the knob downwards prior to moving the lever fully to left and forwards/right and backwards (according to the gearbox in your Caterham model). This is different for models with a sequential gearbox where you will be required to lift the collar and move the stick forwards, release and then repeat which will put the car into reverse gear.

### Precautions while driving

### WARNING!

*DO NOT rest your hand on the gear lever while driving; pressure transmitted from your hand, may cause premature wear to the gear selector mechanism.*

*DO NOT rest your foot on the clutch pedal while driving; excessive wear to the clutch will result!*

## 5/6 speed and sequential gearbox



Standard 5 Speed.

Standard 6 Speed.

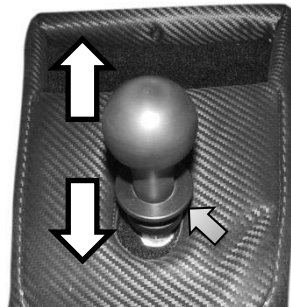

6 speed sequential:

### Sequential Gearbox Operation.

*Arrows are for illustration only:*

To shift up, pull away from dashboard (downwards arrow indicated)

To shift down, push towards dashboard (upwards arrow indicated)

To select neutral and reverse gears, it requires the gearbox to be in first gear. Lift the 'detent' collar at the base of the gearstick as shown by the diagonal arrow and push away to select either neutral or reverse. A 'half movement' downshift will select neutral, as shown by 'N' on the display.

A full movement downshift will go through neutral and select reverse and be shown as 'R' on the display.

*Note: If car is in neutral, wait for 5-10 seconds with clutch up to ensure gearbox is spinning before selecting reverse/first or the gearbox will fail to engage a gear.*

## Fuel

All Caterham Seven models run on unleaded petrol, 95 RON (minimum). Higher performance Caterham Sevens in our range require high octane unleaded petrol. Please refer to the [useful information](#) section for the recommended fuel for your Caterham model.

### **WARNING!**

*USE ONLY UNLEADED PETROL. Serious damage to the catalytic converter will occur if incorrect fuel is used.*

### Fuel Filling

Always fill the tank SLOWLY until the filler nozzle automatically cuts-off the fuel supply. DO NOT attempt to fill the tank beyond this point or spillage could result due to expansion of the fuel.

The filler tube is designed to accept a narrow filler nozzle of the type found on pumps that deliver ONLY unleaded fuel. A flap lies across the filler neck; insert the filler nozzle sufficiently to fully open the flap before filling.

### **WARNING!**

*DO NOT fully fill the tank if the car is to be parked on a slope in direct sunlight or high ambient temperature – expansion of the fuel could cause spillage.*

### Filling difficulties

The fuel delivery rate of filling station pumps can vary significantly from one garage forecourt to another. This coupled with the fact that modern pumps are equipped with a sensor which automatically cuts off the supply as soon as turbulence is detected in the upper part of the car's filler neck could result in isolated fuel filling problems.

If individual owner's experience difficulty, the following advice may be useful:

- Hold the filler gun with the trigger directly below the nozzle (at right angles to the ground). Twisting the gun to either side is unlikely to ease the filling process.
- Fill the tank slowly – DO NOT fully squeeze the trigger.

## Fuel Compatibility Identification

Before refuelling, check the symbol (where provided) adjacent to the filler cap, also shown below, and compare them with the symbol shown on the petrol pump (where provided) to ensure compatibility.



## Braking System

The hydraulic braking system operates through dual circuits; if one circuit should fail, the other will continue to function. However, in the event of a brake failure where only one circuit is operational, the car should ONLY be driven with EXTREME CAUTION to pull off the road.

### Brake pads

Brake pads and linings require a period of bedding in. For the first 500 miles, avoid situations where heavy braking is required.

Remember that regular servicing is vital to ensure that the brake components are examined for wear at the correct intervals and changed whenever necessary to ensure optimum safety and performance.

### **WARNING!**

*DO NOT rest your foot on the brake pedal while driving; this may overheat the brakes, reducing their efficiency and causing excessive wear.*

### Handbrake

The handbrake operates on the rear wheels only and should not require adjustment. To apply the handbrake, pull the lever up. Always apply the handbrake FULLY whenever you park the car. To release, pull the lever up slightly, depress the button and fully lower the lever.

### **WARNING!**

*DO NOT drive with the handbrake applied; this could damage the rear brakes.*

## 2. Useful information

### Specifications

	170	Academy	270/275/280	310	360	420	480/485	620
<b>Engine Type</b>	3 cyl-in-line	4 cyl-in-line	4 cyl-in-line	4 cyl-in-line	4 cyl-in-line	4 cyl-in-line	4 cyl-in-line	4 cyl-in-line
<b>Capacity</b>	658cc	1596cc	1596cc	1596cc	1999cc	1999cc	1999cc	1999cc
<b>Bore</b>	64.0mm	79.0mm	79.0mm	79.0mm	87.5mm	87.5mm	87.5mm	87.5mm
<b>Stroke</b>	68.2mm	81.4mm	81.4mm	81.4mm	83.1mm	83.1mm	83.1mm	83.1mm
<b>Cylinder Head</b>	12v DOHC	16v DOHC	16v DOHC	16v DOHC	16v DOHC	16v DOHC	16v DOHC	16v DOHC
<b>Compression Ratio</b>	9.1:1	11.0:1	11.0:1	11.0:1	10.8:1	10.8:1	13.0:1	9.2:1
<b>Maximum Power</b>	84bhp@ 6500rpm	125bhp@ 6900rpm	134bhp@ 6800rpm	152bhp@ 7000rpm	180bhp@ 7400rpm	210bhp@ 7600rpm	237bhp@ 8500rpm	310bhp@ 7800rpm
<b>Maximum Torque</b>	85lbf@ 4500rpm	117lbf@ 4900rpm	118lbf@ 4100rpm	124lbf@ 5600rpm	143lbf@ 6100rpm	150lbf@ 6300rpm	152lbf@ 6300rpm	220lbf@ 6100rpm
<b>Maximum RPM</b>	6500rpm	6800rpm	6800rpm	7500rpm	7600rpm	7600rpm	8500rpm	7800rpm
<b>Induction System</b>	Single butterfly	Single butterfly	Single butterfly	Single butterfly	Single butterfly	Single butterfly	Four port roller barrel	Supercharged
<b>Lubrication system</b>	Wet sump	Wet sump	Wet sump	Wet sump	Wet sump	Dry sump	Dry sump	Dry sump
<b>Fuel Type</b>	Unleaded 95 RON	Unleaded 95 RON	Unleaded 95 RON	Unleaded 95 RON	Unleaded 95 RON	Unleaded 95 RON	Unleaded 95 RON	Unleaded 98 RON

## Technical data

### Vehicle type

2 Seater, convertible sports car.

### Construction

Tubular steel space frame.

Aluminium panels with aluminium honeycomb cockpit side impact protection.

GRP (Glass-reinforced plastic) or Carbon fibre nosecone and wings.

### Dimensions

	Seven 170	Seven (except 170) Standard S3 chassis Road suspension	Seven (except 170) Standard S3 chassis Sport and Track suspension	Seven (except 170) Wide-bodied S5 chassis	CSR
Wheelbase (mm)	2225	2225	2225	2305	2315
Front Track (mm)	1220	1270	1336	1446	1505
Rear Track (mm)	1301	1336	1336	1446	1465
Length (mm)	3100	3100	3100	3300	3300
Width (mm)	1480	1575	1575	1685	1685
Height (Hood up) (mm)	1165	1115	1115	1140	1140
Height (Hood down) (mm)	1040	990	990	1015	1015
Turning Circle (m)	10	10	10	11	11
Internal width (mm)	930	930	930	1110	1110
Seat to roof height (mm)	838	838	838	865	865
Luggage capacity (ltr)	120	120	120	130	130

**Braking system (All models excluding 170)**

Twin circuit, equal split front/rear, with system warning of low fluid level. Discs front and rear.

**Braking system (170 only)**

Twin circuit, equal split front/rear, with system warning of low fluid level. Front discs and rear drums.

**Parking brake**

This operates on the rear wheels and is actuated by hand lever on all models

**Front Suspension (Excluding CSR)**

Adjustable double wishbone with Coil springs over dampers with anti-roll bar.

*Optional - Dampers with adjustable ride height collars*

**Front Suspension (CSR only)**

Pushrod actuated double wishbones with inboard coil springs over damper units and anti-roll bar

**Rear Suspension (excluding 170 and CSR)**

De Dion axle located by lower 'A' frame & radius arms or 'A' Frame & Watts linkage (620 only)

Progressive Coil springs over dampers.

*Optional - Dampers with adjustable ride height collars*

*Optional - Adjustable anti-roll bar.*

**Rear Suspension (170 only)**

Live axle located by lower 'A' frame & radius arms. Progressive Coil springs over dampers.

*Optional - Dampers with adjustable ride height collars.*

**Rear Suspension (CSR only)**

Independent double wishbone with progressive coil spring over damper units.

**Steering mechanism**

Rack and Pinion

Turns lock to lock Standard 2.46

**Road wheel nut torque**

62lbft / 85Nm

**Electrical**

12 Volt, Negative earth

Alternator outputs

- 70 Amps – 270/275/280/310/Academy
- 40 Amps – 360
- 60 Amps – 170/480/485/620

Battery Capacity

- 30 amps/hrs

**Manual transmission (excluding 170)**

All models excluding 170 – Hydraulic clutch actuation

170 only – Cable clutch actuation

### Wheels - Tyres - Pressures

WHEELS	SIZE/TYRE	TYRE SIZE	TYRE MODEL	TYRE PRESSURE*	
				FRONT	REAR
13" Apollo	6J x 13"	185/55R13 W	Avon ZZS & ZZR	23	23
13" Apollo	8J x 13"	215/55R13 W	Avon ZZS & ZZR	-	23
14" Juno	4.5J x 14"	155/65R14 T	Avon ZT5	22	26
14" Classic	6J x 14"	185/60R14 V	Avon ZT5	20	20
15" Orcus	6.5J x 15"	195/50R15 W	Avon ZZS	18	18
15" Vulcan front	6.5J x 15"	195/50R15 W	Avon ZZS	24	-
15" Vulcan rear	9J x 15"	245/40R15	Avon ZZS	-	23

*\*All tyre pressures quoted are for cold condition*

### Gearbox ratios

	5 SPEED Seven 170 only	5 SPEED All models (except 170)	6 SPEED All models	6 SPEED SEQUENTIAL Seven 620R
1	5.11	3.14	2.69	2.07
2	3.02	1.89	2.01	1.60
3	1.91	1.33	1.59	1.30
4	1.26	1.00	1.32	1.09
5	1.00	0.81	1.13	0.95
6	-	-	1.00	0.83
R	5.15	3.37	2.96	2.07

### Final Drive Ratio:

5 speed	6 seed (sequential)	Suzuki (170)
3.91	3.62	3.9

**Table 5: Fluid Capacities**

Fuel Tank S3 Chassis	36 L	Gearbox 5 speed – 160/165/170	1.2 L
Fuel Tank SV & CSR Chassis	41 L	Cooling System without heater – 160/165/170 only	4.0 L
Oil (incl Filter) – 270/275/280/310/Academy	4.0 L	Cooling System without heater – exc 160/165/170 and CSR	4.5 L
Oil (incl Filter) – 340/360 wet sump	5.5 L	Cooling System with heater – exc 160/165/170 and CSR	5.1 L
Oil (incl Filter) – 160/165	3.0 L	Cooling System – CSR only	5.5 L
Oil (incl Filter) – 170	2.35 L	Differential – All models exc 160/165/170/620R	0.8 L
Oil (incl Filter) – 360/420/485/620 dry sump	7 L	Differential – 620R	1.2 L
Gearbox 5sp / 6sp	1.9 L	Differential – 160/165/170	1.3 L
Gearbox Sequential 6sp	1.2 L		

**Recommended fluid specification**

	170	270/275/310 Academy	340/360 420/485	620S	620R	420 Race
Engine	MOTUL 8100 X-CLEAN+ 5W30	MOTUL 8100 Eco-nergy 5W-30	MOTUL 8100 Power 5W-50			
Supercharger	N/A			ROTEX SX 150	N/A	
Gearbox	MOTUL Gear 300 75W-90				MOTUL Gear Competition 75W-140	
Differential	MOTUL Gear 300 LS 75W-90					
Brake & Clutch Fluid	MOTUL DOT 3 & 4					
Coolant	MOTUL Auto Cool Optimal					

# MOTUL

**NOTE:** Gearbox and differential fluid capacities are approximate and the correct level should be obtained via the level plug

Sadev gearbox oil changes: Prior to every Track day and every race event.

Fluid capacity table should be used as a guideline for initial fill, correct Engine oil level or coolant level should be achieved by following the procedure mentioned on the page number 37.

## Track use

### Enjoying track days and competing in your Caterham Seven.

Due to the difficulty - and illegality - of using the Caterham Seven's full performance on the public roads, many owners choose to use their cars in competition events, such as circuit racing, sprints and hill climbs, as well as non-competitive track days.

### Motorsport

As an introduction to Motorsport, Caterham Cars launched the UK Academy series in 1995; a race series exclusively for novice drivers in identical Caterham machinery. The Academy package comprises of the car and a complete multi-discipline season taking the driver from total novice, through the licence process and training, on to becoming a bona fide race driver. It has become the most successful programme of its type in Europe, turning out more than 50 new racers each year.

The success of the Academy has led to a complete 'ladder' of Caterham Motorsport forming in the UK to accommodate all. Ex-Academy drivers typically continue into the Roadsport championship, a full race series tailored for the newly experienced drivers, in the same car with minor modifications. Tracksport follows with yet further modifications and then Supersport with further upgrades and modifications to the same Academy vehicle. The Championships have been designed to promote close and cost-effective racing by virtue of the strict regulations and the use of sealed engines.

Beyond Roadsport, Tracksport and Supersport, which use the same Academy based cars, is the Superlight R300 championship which uses its own dedicated Superlight R300 model. The Superlight R300 is Caterham's premier UK race series and uses a fearsome 175bhp engine with a Sadev sequential gearbox, coupled to a limited-slip differential. It also has bespoke race suspension and Avon ZZR tyres developed specifically for the car to deliver phenomenal performance.

Caterham Sevens are also highly popular for hillclimb and sprint events, from club to national level. These events are run solely against the clock, with one car on the course at a time divided into a range of classes.

The owners club has its own sprint championship which is the largest single make series of its kind in the UK.

The Motor Sports Association (MSA) is responsible for all forms of motorsport in the UK including all the above, and in order to compete, a competition licence must be held. To hold a 'speed' licence for hillclimb and sprint events you only need to pay the relevant fee. For a race licence however a one-day ARDS driving course must be completed and you will need to pass a medical examination with a doctor. Full details can be obtained from the MSA or Caterham.

### Track days

Track driving days give owners the opportunity to experience all the performance and handling that their car can deliver, in a safe and legal environment. Days are generally operated by Track Day Organisers (TDO's), companies that specialise in hiring a circuit for a day, then selling spaces to the general public. TDO's can be found by contacting the circuits, or an internet search. As the quality of service and time varies, word of mouth recommendation is a valuable medium. A day will either be formed of 20 minute sessions in the hour (for novice, intermediate and experienced), or 'open-pit lane' which allows the owner to take as much track time as they want. In the latter case, we would recommend no more than 20 minutes at a time as personal fatigue can set in and concentration wander. Remember to drink plenty of fluids.

If you would like to partake in a track or experience day in a Caterham other than you own then we have just the solution. We offer a factory Caterham Experience which operates from Silverstone. This is a perfect opportunity for Caterham and driving enthusiasts to improve and hone their driving skills. For more information either visit the Caterham website on [www.caterhamcars.com](http://www.caterhamcars.com) or speak to your local Caterham representative.

The Caterham Seven is ideally suited to track days and it can be almost guaranteed that there will be a Caterham at every single day! The light weight and race bred design means that the car can be driven to the circuit, used all day and driven home with complete confidence. These same qualities mean that Caterhams are typically quicker than most cars on circuit, including much more powerful exotics.



As trackdays cater for the general public in their regular road cars, only personal safety equipment (such as a crash helmet) is a requirement. However, many owners choose to make use of race-developed safety enhancements for peace of mind. Caterham would recommend the following options if you intend using your car on circuit:

- Race harness safety belts (4 point or 6 point)
- Track day roll-over bar
- Arm restraints
- Battery master switch

Further safety enhancements include:

- Plumbed-in fire extinguisher
- Full race roll-cage
- Honeycomb fuel tank protection or bag tank
- Honeycomb floor impact protection panels
- Rear wheel protection bar
- Bespoke seat

All these parts, along with advice, are available from Caterham Aftersales or by visiting the online store.

Whilst a Caterham is perfect for track use, there are a number of essential checks that should be made to ensure that your day passes smoothly:

- Wheel nuts - must be torqued to the correct setting (see [Technical Data](#)). Check after every session.
- Tyre pressures – check the hot temperature immediately after a session. The tyre pressure will increase beyond that of normal road use and may need releasing a little. Avon CR500s should be no more than 22-24psi hot, while Avon ZZR's should be no more than 29-31psi hot. For more road orientated tyres, 28psi hot typically gives the best control.
- Oil and coolant. These should be filled to maximum marks and checked regularly.
- Remove all loose objects from boot area
- Check brake pad wear and fluid level

Before taking to the track it is wise to give the car a general 'spanner check' to ensure everything is tight, especially areas noted below:

- Lower front diff bolts should be torqued up and secure. (CSR / 620R only, see pages 48 & 49)
- Top wishbone ball joint nuts should be torqued and secure. (See pages 48 & 49)
- Lower front damper bolts should be torqued up and secure. (See pages 48 & 49)
- Grease prop shaft regularly.

Track usage is among the toughest environments for any vehicle and even though your Caterham Seven has been designed around this environment it is vital that careful monitoring of the gauges is carried out whilst driving under these harsh conditions. A rule of 1 track mile equals 10 road miles should be considered in relation to service schedules.

It would also be prudent to carry out the above checks before, whilst and after visiting the track.

***If in ANY doubt, please contact our Aftersales department for further details on servicing and track use.***

#### **Water temperature**

Always allow the engine to warm up to at least 65°C before using high rpm or full throttle.

#### **Oil temperature**

Once again high rpm or full throttle should not be used until the engine oil temperature is at least 50°C. Oil temperature rises with engine rpm and loading, so it won't come up to temperature at idle like the water. Therefore, if your car isn't fitted with an oil temperature gauge, we would recommend building up the maximum revs used cautiously for the first few laps of use. The oil will come up to temperature quickly. A maximum oil temperature of 120°C is recommended. If track usage causes this figure to be exceeded then fitment of an oil cooler is recommended. This can be carried out by our Aftersales team, speak to Caterham for more information.

#### **Oil changes**

The engine oil should be changed more frequently with cars used on the track. We recommend every 1000 track miles as a minimum. More frequent changes can only be beneficial.

For enhanced track performance, you may wish to upgrade your car to include some of the following as this will improve both your enjoyment and safety whilst on the track.

- 13" wheels fitted with Avon CR500 or Avon ZZR road tyres
- Uprated anti roll bars (front and rear)
- Uprated front or rear springs
- Clutch and throttle pedal stops
- Uprated brake master cylinder
- Race dampers

***NOTE: For track use, cars fitted with uprated brake master cylinder must use race cap to avoid any leaks.***

### 3. Maintenance

In addition to the routine services and inspections described in this book, the following simple checks must be carried out more frequently. You can do this yourself and advice is given on the pages that follow.

#### Under bonnet location –170

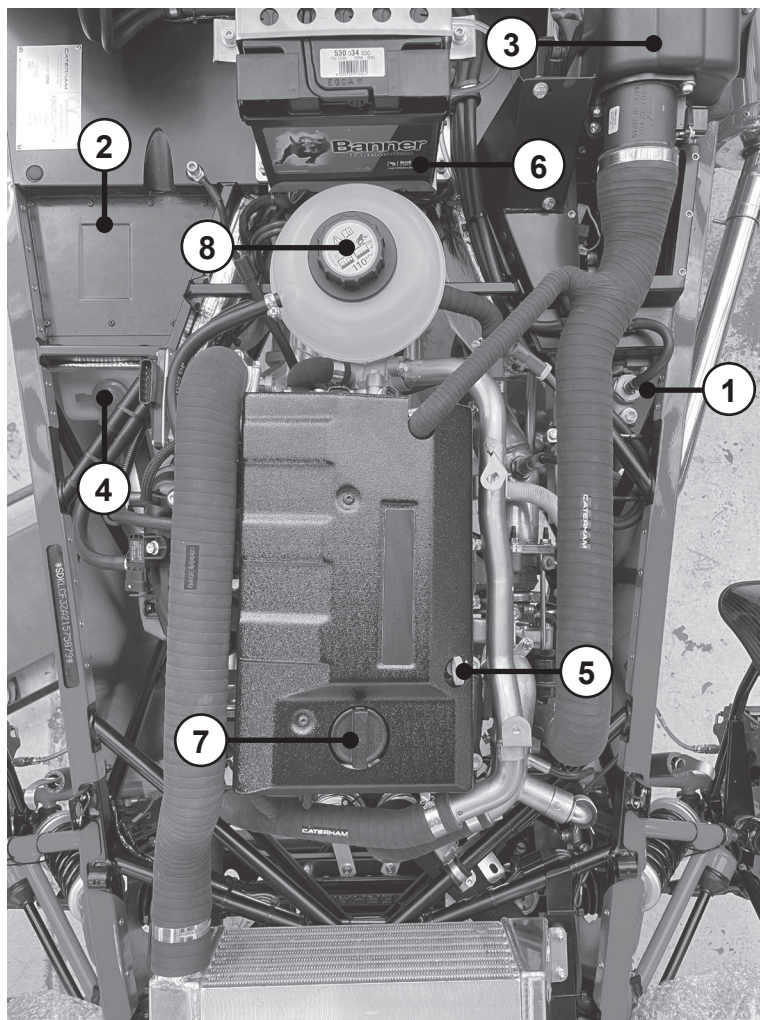

- |  |  |
|--|--|
| 1. Brake fluid reservoir (left hand drive)           | 4. Windscreen washer fluid (left hand drive) |
| 2. Brake fluid reservoir location (right hand drive) | 5. Dipstick                                  |
| 3. Air box   | 6. Oil filler                                |
|  | 8. Coolant filler                            |

Figure 9: Under bonnet location – 275/280

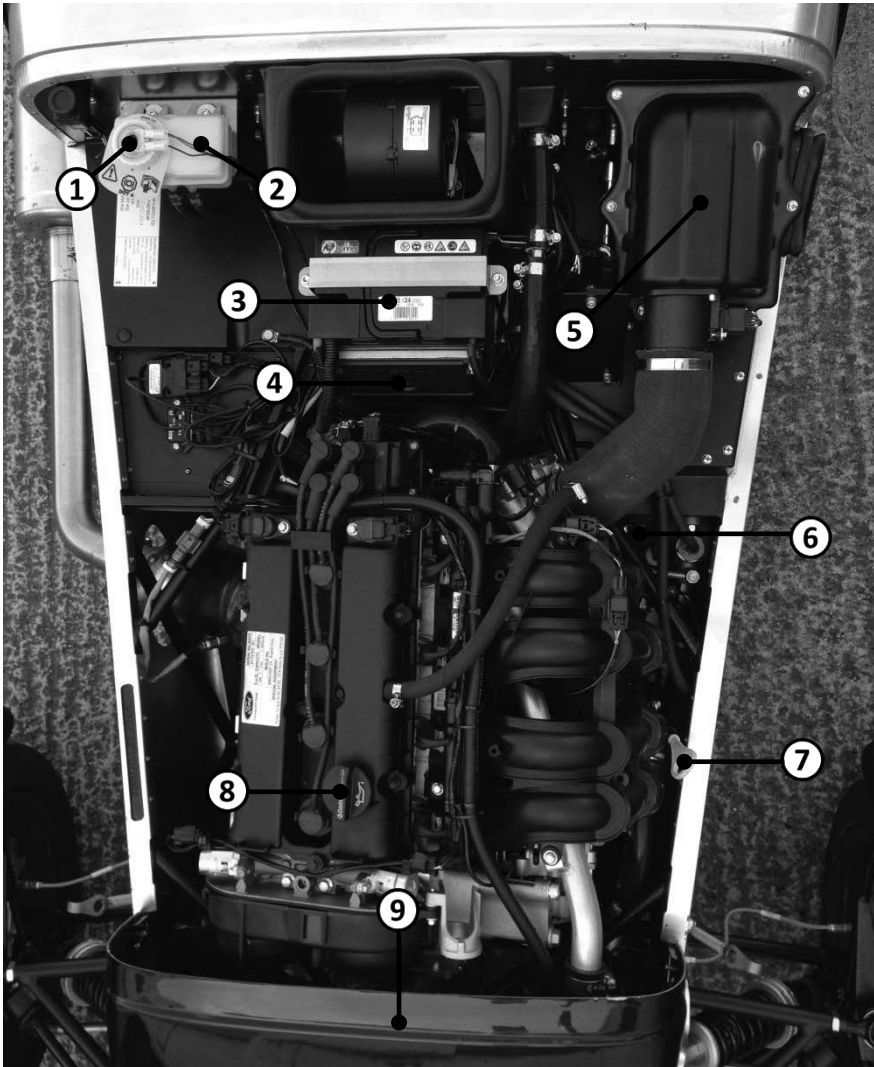

1. Brake fluid reservoir
2. Clutch fluid reservoir
3. Battery
4. ECU
5. Air box

6. Windscreen washer fluid
7. Dip stick
8. Engine oil filler cap
9. Coolant filler cap (under nosecone)

Figure 10: Under bonnet location – 270/310

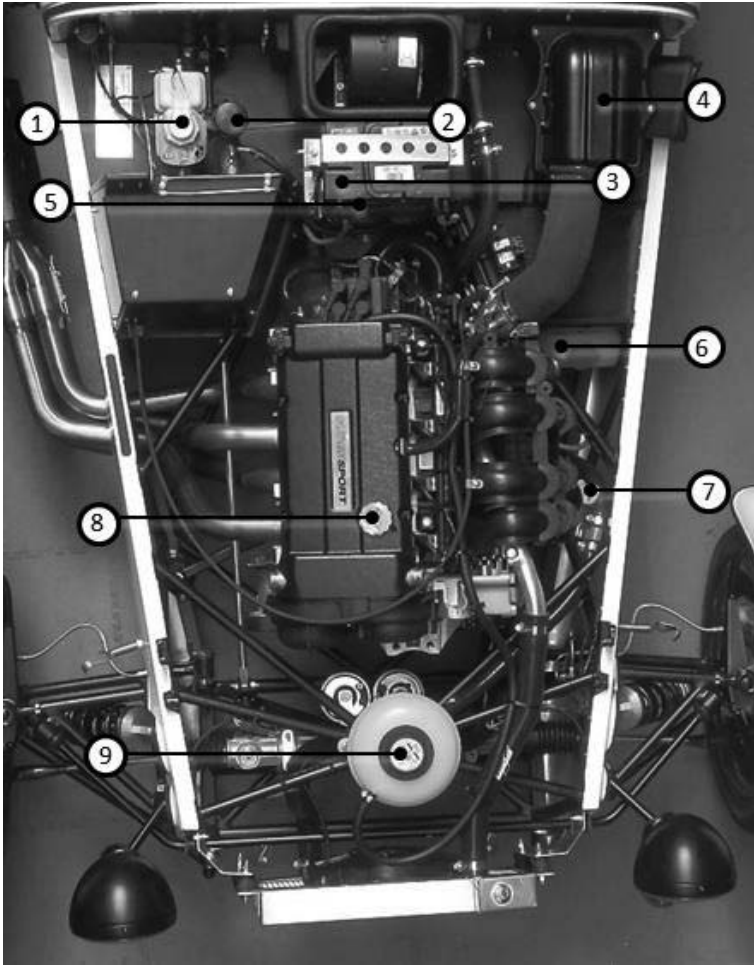

- |                                |                            |
|--------------------------------|----------------------------|
| 1. Brake fluid reservoir       | 6. Windscreen washer fluid |
| 2. Clutch fluid reservoir      | 7. Dip stick               |
| 3. Battery                     | 8. Engine oil filler cap   |
| 4. ECU (Located under battery) | 9. Coolant filler cap      |
| 5. Air filter                  |                            |

Figure 11: Under bonnet location – 355

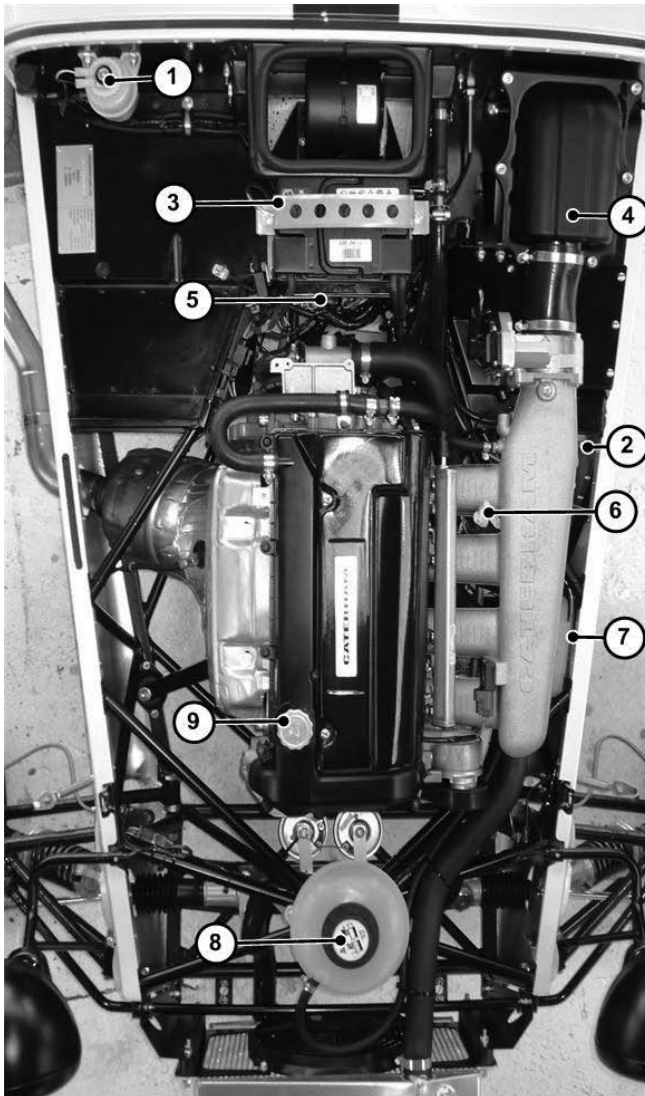

- |                           |                            |
|---------------------------|----------------------------|
| 1. Brake fluid reservoir  | 6. Dip stick               |
| 2. Clutch fluid reservoir | 7. Windscreen washer fluid |
| 3. Battery                | 8. Coolant filler cap      |
| 4. Air box                | 9. Engine oil filler cap   |
| 5. ECU                    |                            |

Figure 12: Under bonnet location – 360/420

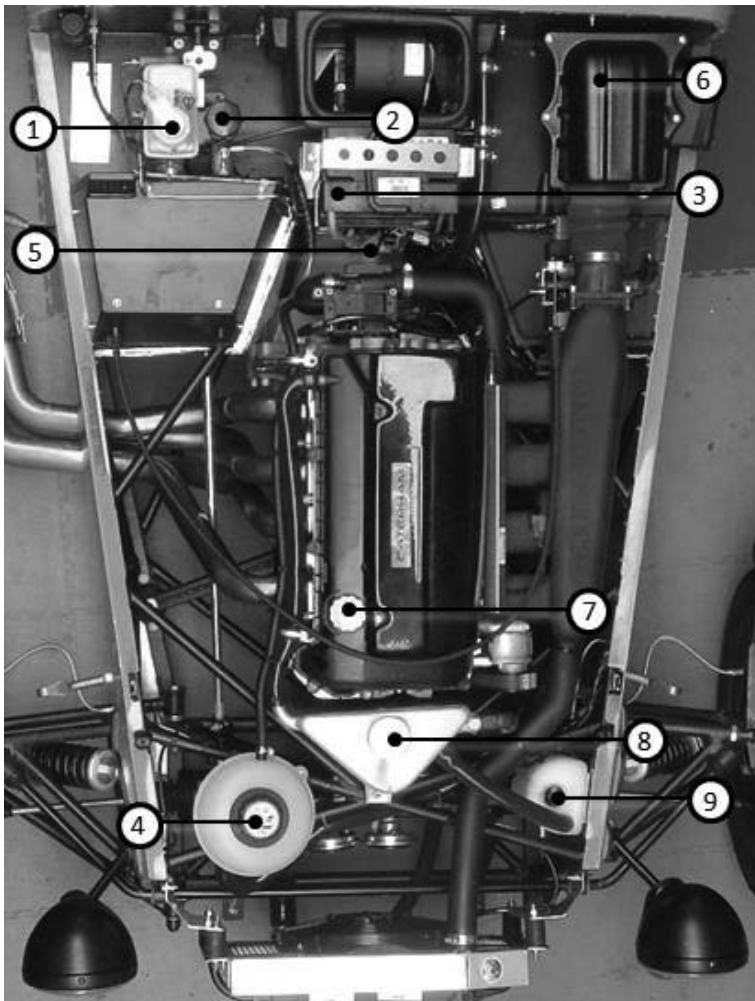

- |                                |  |
|--------------------------------|--|
| 1. Brake fluid reservoir       | 6. Air filter                                |
| 2. Clutch fluid reservoir      | 7. Engine oil filler cap                     |
| 3. Battery                     | 8. Oil tank filler cap                       |
| 4. Coolant filler cap          | 9. Oil catch tank cap (for dry sump systems) |
| 5. ECU (located under battery) |  |

**NOTE:** Under bonnet location for Superlight R400 with dry sump is similar as standard R400 apart from oil tank located near coolant tank and oil cooler in front of the radiator. Also, car pictured has washer bottle located in boot, see following page for location.

Figure 13: Under bonnet location - 485

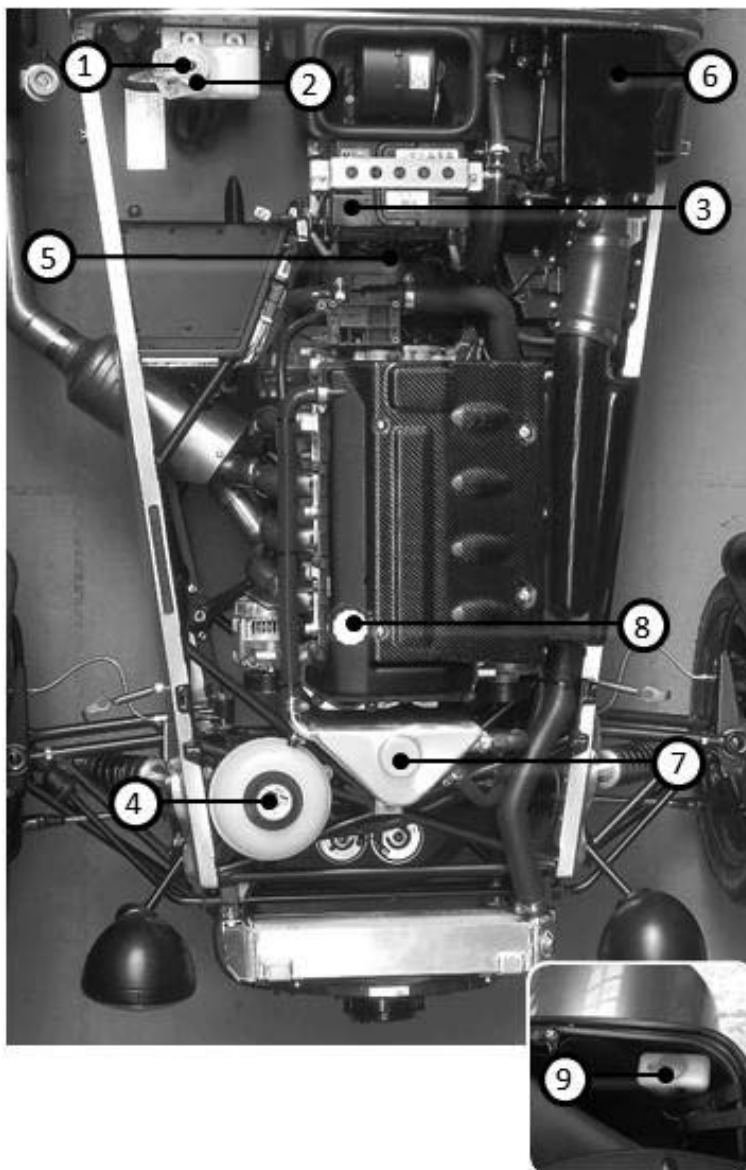

1. Brake fluid reservoir
2. Clutch fluid reservoir
3. Battery
4. Coolant filler cap
5. ECU

6. Air filter
7. Oil tank filter
7. Oil tank filler cap
8. Oil filler cap
9. Washer bottle (located in boot as illustrated)

Figure 14: Under bonnet location – 620

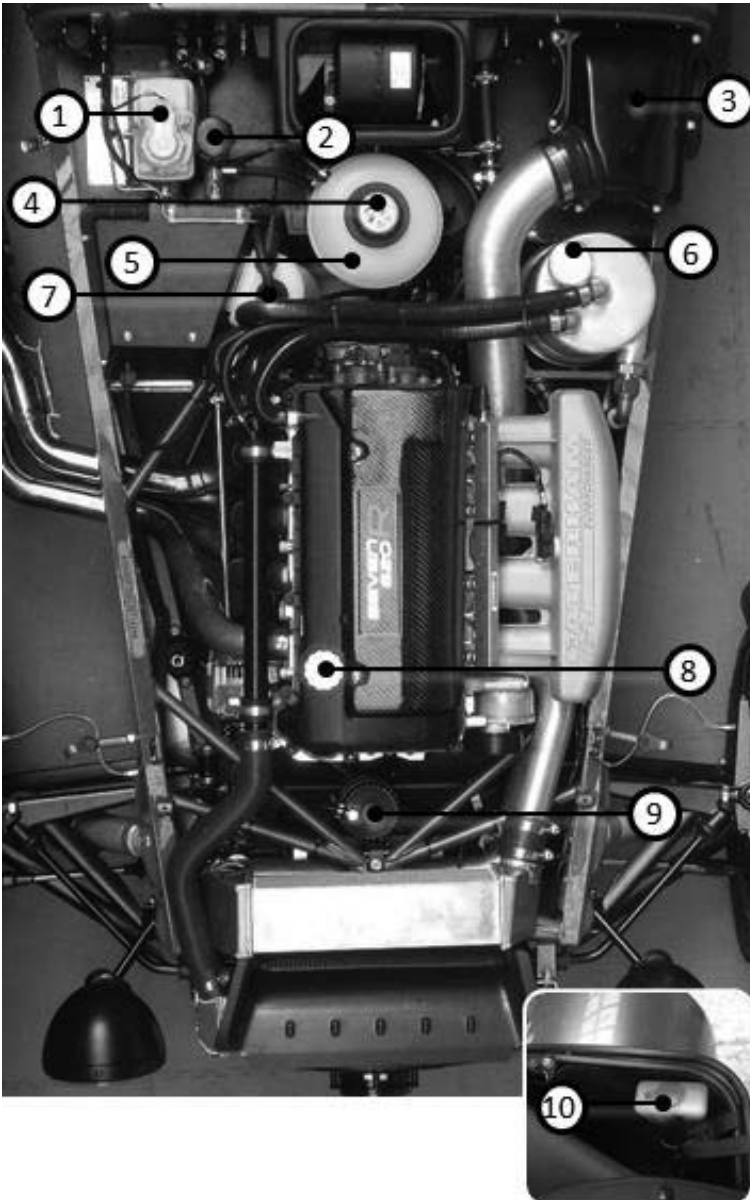

- |                            |  |
|----------------------------|--|
| 1. Brake fluid reservoir   | 6. Oil tank filler cap                             |
| 2. Clutch fluid reservoir  | 7. Oil catch tank                                  |
| 3. Air filter              | 8. Oil filler cap                                  |
| 4. Coolant filler cap      | 9. Supercharger reservoir cap                      |
| 5. ECU (under header tank) | 10. Washer bottle (located in boot as illustrated) |

*Note: Battery is located in passenger foot well.*



### Regular checks:

- Operation of lights, horn, direction indicators, wipers, washers and warning lights.
- Operation of seat belts/harnesses and brakes.
- Look for fluid deposits on the floor beneath the car, which may indicate a fluid leak.

### Weekly checks:

- Engine oil level.
- Cooling system level.
- Condition and pressure of tyres.
- Brake fluid levels.
- Clutch fluid levels.
- Screen washer reservoir level.

**NOTE:** Any significant or sudden drop in fluid levels, or uneven tyre wear, should be reported to Caterham without delay.

### Emission control

Your car is fitted with emission control equipment designed to meet specific legal requirements. You should be aware that unauthorised replacement, modification or tampering with this equipment by an owner or motor vehicle repairer, could be unlawful and subject to legal penalties.

In addition, engine settings must not be tampered with. These have been established to ensure that your car complies with stringent exhaust emission regulations. Incorrect engine settings may adversely affect exhaust

emissions, engine performance and fuel consumption, as well as causing high temperatures, which could result in damage to the catalytic converter and the car.

## Safety in the garage

If you need to carry out maintenance on your vehicle, observe the following safety precautions at all times:

### WARNINGS!

- ALWAYS keep hands, tools and items of clothing, clear of all drive belts and pulleys
- DO NOT touch exhaust or cooling system components until they are cool.
- DO NOT touch electrical leads or components with the ignition switch turned on.
- NEVER leave the engine running in an unventilated area – exhaust gases are poisonous and extremely dangerous.
- **DO NOT work beneath the car with a vehicle lifting jack as the only means of support.** (See axle stand positioning).
- Ensure sparks and naked lights are kept away from the engine compartment.
- Remove all metal wrist bands and jewellery, before working in the engine compartment and NEVER allow the battery terminals, or leads, to make contact with tools or other metal parts of the car.

### Front and Rear axle stand positioning

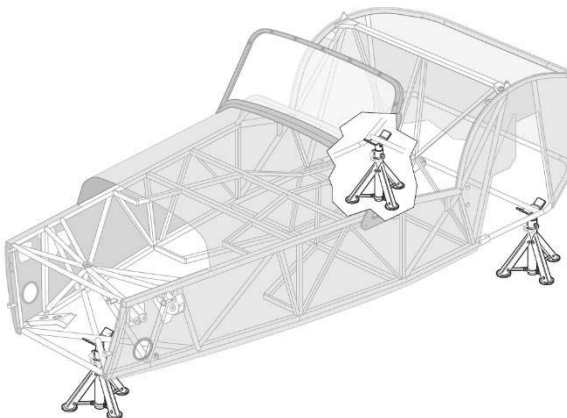

## Poisonous liquids

Most liquids used in motor vehicles are poisonous and should not be consumed or brought into contact with open wounds (these substances include; battery acid, anti-freeze, brake fluid, petrol, oil and windscreen washer additives). Obey all instructions printed on labels and containers!

## Used engine oil

Prolonged contact with engine oil may cause serious skin disorders, including dermatitis and cancer of the skin. Wash thoroughly after contact.

## Checking fluid levels

Due to the nature of the Caterham Seven with its high revving engines and extreme cornering speeds it is vitally important that the correct engine oil level is maintained at all times.

### Engine oil levels

#### These cannot be checked too often

We recommend that it be checked at least every 500 miles and before any long journey or before every session at a track day.

There are several different oil systems fitted to the Seven, each of which requires a different means for checking the level. It is important that you are clear on the correct procedure for the system fitted to your car.

- Standard wet sump arrangements & engines fitted with oil/air separator tank
- Engines with dry sump bell tank and swirl tower.

#### Engines with standard wet sump arrangement

- Start the engine and run until the normal operating temperature is achieved (90-100°C)
- Stop the engine and remove the dipstick from its tube and wipe clean before re-dipping, please leave the dipstick in place for 30sec this will ensure that the correct indication is achieved
- The oil should be at the maximum level at all times. (As a guide the difference between min and max is approximately 1/2 litre)
- If required, oil should be added via the oil filler cap on the top of the engine and must be of the correct specification of oil for your engine type. (See [technical data](#))
- It is advisable to add a small amount at a time and recheck by repeating the above procedures until the correct level is achieved
- Care should be taken not to overfill the engine with oil.

Figure 15: Wet sump dipstick level indicator

- Always make sure the oil filler cap and dipstick are fitted back in place before restarting the engine
- Any spilt oil should be wiped up immediately.

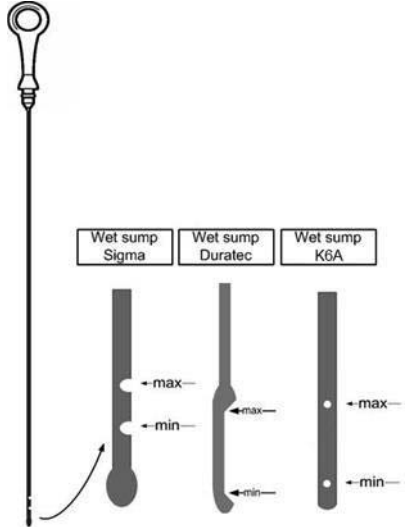

Figure 16: Dry sump tank cap and level indicator for 360/420/485 only



### Engines with dry sump tank

Start the engine and run it until the normal operating temperature achieved (90-100°C). Turn the engine off, wait 30sec and take reading from the dip stick, you should be within the hot range. Top up the oil if required and repeat.

**NOTE:** *With this system the oil level must be checked within one minute of the engine being switched off otherwise the oil will start to drain back into the engine and a false reading will be obtained. Should this be the case restart the engine again and let it run for approximately one minute before repeating the checking procedure.*

### Supercharger oil level checking and maintenance (For 620 only)

To check the oil level on the supercharger system requires the engine to be running and held between 2 – 3000rpm. The correct oil level is between the min and max markings of the dipstick measured with the thread of the cap fully engaged. Check the oil system regularly.

#### **IMPORTANT!**

*Always keep the oil level between minimum and maximum.*

*Overfilling the canister may cause oil leaks from the oil canister and too little may cause damage to the supercharger.*

**Figure 17: Coolant expansion bottle**

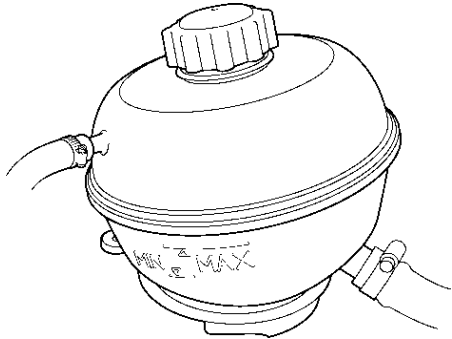

### Coolant check & top-up

The coolant level should be checked weekly when the system is cold and topped up with appropriate coolant (see technical data). Top up to the 'MAX' mark shown on the exterior of the reservoir. If the level falls appreciably during a short period; suspect leakage or overheating and contact Caterham to arrange for factory trained technician to examine the vehicle.

### Anti-freeze

The anti-freeze content of the coolant must be maintained all the year round. Caterham use Millers Alpine Red and Ford Superplus premium (ready mixed), however, if a water/anti-freeze mix is substituted for any reason a minimum of 50% anti-freeze is required. To ensure that its anti-corrosion properties are retained, the anti-freeze content should be checked by Caterham once a year. The coolant should be completely renewed every four years.

#### **WARNING!**

- *DO NOT use anti-freeze to any specification other than that recommended (see [technical data](#): recommended fluid specification).*
- *DO NOT add rust inhibitors or other additives to the coolant – these may not be compatible with the coolant or engine components.*
- *DO NOT remove the reservoir cap when the cooling system is hot – escaping steam or water could cause serious injury.*

- *Anti-freeze is poisonous and can be fatal if swallowed. If accidental consumption of anti-freeze is suspected, seek appropriate medical attention immediately.*
- *Take precautions to prevent anti-freeze coming in contact with the skin or eyes. If this should happen, rinse immediately with plenty of water.*
- *Anti-freeze is flammable. Take care not to spill anti-freeze onto a hot engine – a fire may result.*
- *When topping up, avoid spillage onto painted body panels – anti-freeze may damage painted surfaces.*
- *Any spillage should be wiped up immediately.*

### Brake/clutch fluid check & top-up

Fluid level in the brake/clutch reservoir may fall slightly during normal use, but should not drop below the lower level mark. If there is any appreciable drop in level over a short period, consult Caterham.

### Topping-up

Wipe the filler cap clean before removing to prevent dirt from entering the reservoir and then top-up the reservoir to the 'MAX' mark using a recommended fluid: (See [technical data: recommended fluid specification.](#))

Figure 19: Brake fluid reservoir

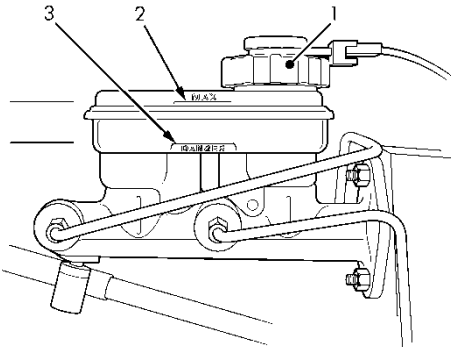

1. Reservoir filler cap
2. 'MAX' – maximum level
3. 'DANGER' – minimum level

For the clutch reservoir, 'Max' and 'Min' levels are highlighted on the outer surface of the reservoir as illustrated.

Use only new fluid from a sealed container (old fluid from uncapped containers or fluid previously bled from the system will absorb moisture and adversely affect performance).

To refit the cap, replace slowly to prevent leakage and screw up by hand only.

Figure 18: Clutch fluid reservoir

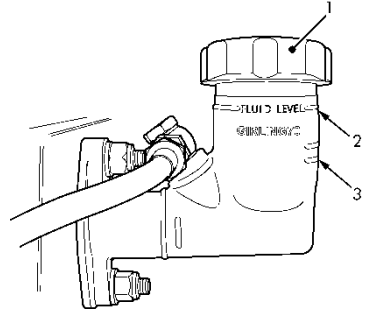

### WARNING!

- *DO NOT drive the car if the fluid level is below the 'DANGER' mark.*
- *Brake/Clutch fluid may damage painted surfaces: Soak up any spillage with an absorbent cloth immediately and wash the area with a mixture of car shampoo and water.*
- *If Brake/Clutch fluid should come into contact with the skin or eyes, rinse immediately with plenty of water.*
- *Brake/Clutch fluid must be completely replaced every after two years, regardless of mileage.*
- *Brake/Clutch fluid is inflammable; do not allow fluid to come into contact with hot components or naked flames.*

## Wipers & Washers

### Windscreen washers

Check the reservoir level at least every week and top-up with a mixture of water and screenwash.

### WARNING!

*Screenwash is flammable, particularly if high or undiluted concentrations are exposed to sparks. Do not allow screenwash to come into contact with naked flames or sources of ignition.*

Body panels may suffer discolouration as a result of screenwash spillage. Take care to avoid spillage, particularly if an undiluted or high concentration of screenwash is being used. If spillage occurs, wash the affected area immediately with water.

**WARNING!**

*Do not use an anti-freeze or vinegar/water solution in the screen washer reservoir – anti-freeze will damage painted surfaces, while vinegar can damage the windscreen washer pump.*

**Washer jets**

Once set, the washer jets should not require further adjustment. If a jet becomes blocked, use a thin wire or pin as a probe to clear the obstruction.

**Wiper blades**

Wash the wiper blades in warm soapy water and periodically check their condition. If signs of hardness or cracking in the rubber are found, or if the wipers leave streaks or unwiped areas on the windscreen during use, then the wiper blades should be replaced. Replacement blades can be purchased directly from Caterham or your local representative.

Clean the windscreen regularly with Autoglym glass cleaner and ensure the screen is thoroughly cleaned before fitting replacement wiper blades.

## Battery

**Battery maintenance**

The battery is designed to be maintenance free, so topping-up is unnecessary. The battery will lose charge if your vehicle is laid up unused. See “Laying your vehicle up for long periods” later in this section.

**WARNING!**

*Batteries contain acid, which is both corrosive and poisonous. If spillage occurs:*

- *On clothing or the skin – remove any contaminated clothing immediately, flush the skin with large amounts of water, and seek medical attention urgently.*
- *In the eyes – flush with clean water immediately for at least 15 minutes. Seek medical attention urgently.*
- *Swallowing battery acid can be fatal unless IMMEDIATE action is taken – seek medical attention urgently.*
- *During normal operation batteries emit explosive hydrogen gas – ensure sparks and naked lights are kept away from the engine compartment.*

- *For your safety remove all metal wrist bands and jewellery before working in the engine compartment and NEVER allow the battery terminals or vehicle leads to make contact with tools or metal parts of the vehicle.*

**WARNING!**

- *DO NOT reverse the polarity of the battery – the electrical system will sustain extensive damage if the battery leads are connected to the wrong terminals.*

**Figure 20: Battery and clamp**

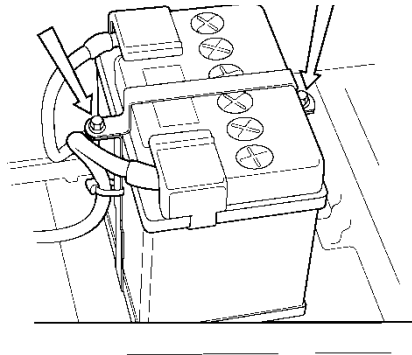

**Battery removal and replacement**

Before disconnecting the battery, switch off all electrical equipment and remove the ignition key.

To remove: disconnect the negative (-) cable first and then the positive (+) cable. When reconnecting, connect the positive cable first and then the negative cable. Do not allow the battery terminals to make contact with metal parts of the vehicle.

To release the battery from the car, undo the two bolts securing the battery clamp and remove the clamp.

When replacing, ensure the battery is fitted the right way round and that the clamp is secure. Tighten the clamp bolts until the clamp is free from movement but do not overtighten.

**Replacement battery**

Only fit a replacement battery of the same type and specification as the original – other batteries may vary in size or have different terminal positions which could cause a fire hazard when connected to the car's electrical system. Replacement batteries can be purchased directly from Caterham or your local representative.

### **Battery disposal**

Used batteries should be recycled. However, batteries are hazardous – you should seek advice about disposal from a Caterham representative or your local authority.

#### **WARNING!**

- *Keep the battery upright at all times – damage will be caused if the battery is tilted more than 45 degrees.*
- *DO NOT run the engine with the battery disconnected, or disconnect the battery while the engine is running.*

### **Battery charging**

Batteries generate explosive gases, contain corrosive acid and produce levels of electric current sufficient to cause serious injury. Whilst charging, always heed the following precautions:

- Before charging, disconnect and remove the battery from the vehicle – charging the battery with the cables connected may damage the vehicle's electrical system.
- Make sure the battery charger leads are securely clamped to the battery terminals BEFORE switching on the battery charger. Do not move the leads once the charger is switched on.
- Whilst charging, shield your eyes or avoid leaning over the battery and keep the area around the top of the battery well ventilated.
- Do not allow naked lights near the battery (batteries generate flammable hydrogen during and after charging).
- When charging is finished, switch off the battery charger BEFORE disconnecting the leads from the battery terminals.
- After charging, leave the battery for an hour BEFORE reconnection to the vehicle – this will allow time for explosive gases to disperse, thereby minimising the risk of fire or explosion.

**NOTE:** *Be aware that a battery will take longer to charge in a cold environment.*

#### **WARNING!**

- *DO NOT charge the battery if it is connected to the car – this may seriously damage the electrical system.*
- *DO NOT charge the battery if it is suspected of being frozen.*

### **Wheels & Tyres**

#### **WARNING!**

**DEFECTIVE TYRES ARE DANGEROUS!**

*DO NOT drive your car if any tyre is excessively worn or damaged, or is inflated to an incorrect pressure.*

*Incorrect tyres can affect the stability and handling characteristics of your car – only fit replacement tyres that are identical to the original specification.*

### **Caring for your tyres**

Always drive with consideration for the condition of the tyres and frequently inspect the tread and side walls for any sign of distortion (bulges), cuts or wear.

The most common causes of tyre failure are:

- Bumping against kerbs
- Driving over deep pot holes
- Driving with under or over-inflated tyres.

### **Tyre pressures**

Correctly inflated tyres will ensure that you enjoy the best combination of tread life, ride comfort, fuel economy and road holding.

Check the pressures at least every week (including the spare wheel if applicable), preferably when the tyres are cold (be aware that the car can be driven up to one mile (1.6 km), before the tyres start to warm up).

Air pressure naturally increases in warm tyres; if it is necessary to check the tyres when they are warm (after the car has been driven for a while, even in cold weather), you should expect the pressures to have increased by between 4 and 6 psi. In this circumstance, DO NOT let air out of the tyres in order to match the recommended pressures.

The recommended pressures are shown in the [Technical data](#) section of this book.

Remember; incorrectly inflated tyres may wear rapidly or unevenly, are more easily damaged, and can seriously affect the car's handling characteristics.

### **Tyre wear indicators**

The tyres on your car have wear indicators moulded into the tread pattern at several points around the circumference and across the width of the tyre.

When the tread has worn down to 1.6 mm, the indicators will come to the surface of the tread pattern, producing the effect of a continuous band of rubber across the width of the tyre.

If running with increased front camber, the inside edges will be more prone to wear and tyres may need replacing sooner as a result if less than 75% of the tyre is over 1.6mm

The indicators provide warning that there is insufficient tread remaining to provide good traction, particularly on wet roads.

**NOTE:** Due to the minimal weight of the Caterham Seven it is more prone to aquaplaning in wet conditions. It is for this reason that we recommend tyres are changed at 2.5mm even though the legal minimum is 1.6mm.

If tyre wear is uneven (on one side of the tyre only), or becomes abnormally excessive, the suspension geometry should be checked.

#### Valve caps

Keep the valve caps screwed down firmly. They prevent dirt from entering the valve.

#### Punctured tyres

Your car is fitted with tubeless tyres, which will normally lose pressure very slowly if penetrated by a sharp object, provided it remains in the tyre. If you are aware of this occurring, reduce speed immediately and drive with caution until the spare wheel or replacement tyre can be fitted. Remember, punctured or damaged tyres must be permanently repaired or replaced, AS SOON AS POSSIBLE!

**NOTE:** All cars are supplied with tyre fix repair spray to repair a small puncture on the tyre surface temporarily. Please follow the instruction on the repair spray can.

Caterham recommend that you replace the tyre rather than repair. A tyre repair may not withstand the performance demands you place upon it.

#### Replacement tyres

Wheel rims and tyres are matched to suit the handling characteristics of the car. Changing the specification of a wheel or a tyre, can adversely affect the car's handling and ultimately your own safety in emergency road situations.

To be safe, ONLY fit replacement tyres that are identical to the original specification shown in 'Technical data' section of this book.

## Changing a wheel and tyre assembly

#### Tools required

- Jack & handle
- Wheel nut spanner

Before you start, ensure that the vehicle is on firm level ground. Always apply the handbrake and put into first gear.

#### Positioning the jack

Position the jack under the jacking point (see illustrations).

Turning the jack screw by hand, raise the jack until the centre of the jack platform fits snugly up to the jacking point. Do not raise the car.

#### Figure 21: Front and rear jack points

##### 24.1) Position of front jacking point

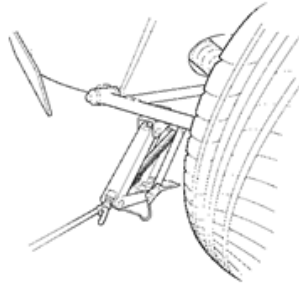

##### 24.2) Position of rear jacking point

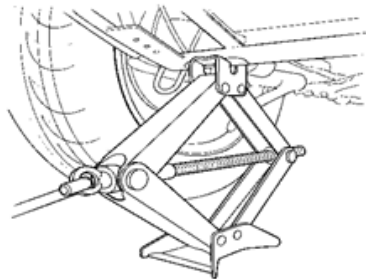

#### Removing and refitting the wheel and tyre assembly

Before raising the vehicle, use the wheel brace to slacken the wheel nuts  $\frac{1}{2}$  a turn anti-clockwise.

Ensure the jack is placed as far inboard as possible when jacking the front of vehicle on lower wishbone.

Attach the jack handle to the jack and turn clockwise until the tyre is just clear of the ground.

#### WARNING!

- Do not allow the jack to tilt on its base.

Remove all the wheel nuts and the wheel. (Do not place the wheel face down on the ground as this may cause scratching to the surface of the wheel).

Replace the wheel and wheel nuts (tapered end towards the wheel) and tighten the nuts until the wheel is seated firmly against the hub.

Lower the car by turning the jack handle anti-clockwise then remove the jack from under the car. Finally fully tighten the wheel nuts in a diagonal sequence.

**WARNING!**

- *Always check the tyre pressures before driving off or as soon afterwards as possible.*
- *Whenever refitting the wheel nuts it is imperative that they are tightened to the correct torque. Check wheel nut torque as soon as possible.*

**WARNING!**

*Always observe the following precautions!*

- *Choose a safe place to stop, away from the main thoroughfare, and ensure your passenger gets out of the car and waits in a safe area, away from other traffic.*
- *Switch on the hazard warning lights to alert other road users. Apply the handbrake and engage first gear.*
- *Ensure the jack is positioned on firm, level ground. Do not position the jack on metal gratings or manhole covers, or use additional material between the base of the jack and the ground.*
- *If jacking on a slope, place chocks at the front and rear of the wheel diagonally opposite the one to be removed.*
- *Care must be taken to avoid accidental contact with any underbody parts, especially the hot exhaust system components, likely to cause personal injury during the raising or lowering of the car.*

**WARNING!**

- *NEVER jack the car with passengers inside!*
- *NEVER work beneath the car with the jack as the only means of support. The jack is designed for wheel changing only!*



## Cleaning and car care

### Washing your car

**WARNING!** Take care to avoid contact with a hot exhaust system when washing the car.

Road dirt, oil, and deposits from birds and trees, can permanently spoil the paint finish. Wash your car frequently, using a clean, grit free sponge and generous quantities of cold or lukewarm water, containing car shampoo/conditioner. Rinse and dry off with a chamois leather.

- In hot weather, DO NOT wash the car in direct sunlight – move the car into the shade!
- DO NOT use detergent soap products or washing up liquid.

During winter months when salt has been used on the roads, use a hose to wash the underside. Pay particular attention to wheel arches, panel seams and to removing accumulations of mud.

When using a hose, do not direct the jet into the heater air intake ducts, or through the wheels onto the brake components.

**WARNING!** Some high pressure cleaning systems available on garage forecourts are sufficiently powerful to damage fragile components. Never aim the water jet directly at components that might easily be damaged.

### Removing tar spots

Use a tar removal product to remove tar spots and stubborn grease stains from paintwork. Then wash immediately with soapy water, to remove all traces of the spirit.

### Body protection

After washing, inspect the paintwork for damage. Treat paint chips and scratches with touch-up paint. If the damage has revealed bare metal, use a coloured primer first, then apply the base coat and finish off with a lacquer pencil, if appropriate. Carry out this treatment after washing, but before polishing or waxing. Take care to ensure that car polish and body cleaning compounds are not applied to the window glass or seals.

### Carbon

Carbon wings, nosecone and other carbon elements should not be polished other than with a wax or specifically abrasive-free car polish. Most car polishes contain very mild abrasives that will damage the surface, leading to discolouration and imperfections.

### Windscreen

Regularly clean the windscreen, inside and out, using an approved glass cleaner.

### Hood/Sidescreen

The windows in the hood and sidescreen are made of plastic and should be cleaned with soapy water. Never use an abrasive cleaner on these windows.

### Mirrors

Mirror glass is particularly susceptible to damage; DO NOT use abrasive cleaning compounds or metal scrapers.

### Wiper blades

Always clean the windscreen before fitting replacement wiper blades. Regularly wash the wiper blades with warm soapy water (NEVER use a spirit or petrol based solvent).

### Looking after the interior

**Vinyl/plastic/cloth-faced materials:**  
Clean with diluted upholstery cleaner.

### Leather:

Seats, steering wheel and any trim features should be cleaned with warm water and a non-detergent soap. Dry and polish the leather with a clean, dry, lint-free cloth.

### Alcantara panels:

Dab, do not rub and try not to over wet the surface. DO NOT use petrol, detergents, furniture creams or polishes!

### Carpets:

Sweep regularly with a brush or vacuum cleaner and clean with diluted upholstery cleaner

### **Seat belts:**

Extend the belts and use warm water and a non-detergent soap to clean. On no account use bleaches, dyes or cleaning solvents – these can weaken the belt webbing. Finally, allow the belts to air-dry naturally and do not retract them, or use the car, until they are completely dry.

## **Laying your vehicle up for long periods**

Should your Caterham be laid up unused for more than 12 weeks at a time then we recommend the following precautionary measures be taken to avoid unnecessary deterioration:

1. Ensure the bodywork and trim are properly cleaned and protected to prevent corrosion.
2. Erect and correctly tension the weather equipment to prevent storage damage.
3. Raise car off the ground and place on axle stands taking the weight of the car off of the tyres.
4. Check Anti-freeze content as this will not only protect your engine from the cold but most anti-freeze also includes additives to prevent corrosion inside the cooling system.
5. It is important that the battery charge level is maintained during storage. Recharging of the battery may not be successful if the battery is allowed to discharge below a certain level.

We recommend that a battery conditioner is fitted to the vehicle whilst in storage as this unit will maintain a minimum charge at all times. Suitable devices are available from Caterham or your local representative. Should this option not be available to you then the battery should be disconnected and charged periodically. See section on [battery removal and replacement](#).

6. Ensure that the handbrake is off and that all the wheels turn freely as this will help to prevent the brake pads from sticking to the discs in cold and damp conditions.

### **After long periods of storage**

Before reusing your vehicle after storage, the following checks should be carried out:

1. Tyre pressures and condition.
2. Check all fluid levels.

**NOTE:** *Should your vehicle have been laid up in excess of 6 months then we strongly recommend that the engine oil and oil filter are changed and the braking system is checked. A full safety check is available from Caterham Aftersales.*

## **Travelling abroad**

In certain countries, it is illegal to fit parts which have not been made to the vehicle manufacturer's specification.

Owners should ensure that any parts or accessories fitted to the car while travelling abroad will also conform to the legal requirements of their home country.

If travelling abroad, please ensure that you are carrying the appropriate compulsory equipment required in the country in which you are driving. More information on this can be found online by visiting <https://www.gov.uk/driving-abroad>

**NOTE:** *There are certain items you are required to carry with you whilst travelling abroad. Please consult your motoring organisation for the latest requirements.*

## 4. In an emergency

### Emergency starting

#### **WARNING!**

- During normal use, batteries emit hydrogen gas, sufficient to cause severe explosions capable of causing serious personal injury – ensure sparks and naked lights are kept well away from the engine compartment.
- DO NOT disconnect the discharged battery.
- Make sure BOTH batteries are of the same voltage (12 volts) and that the jump leads are approved for use with 12 volt car batteries.
- To avoid injury, always adopt the following procedure when using jump leads.

Figure 22: Jump lead connection

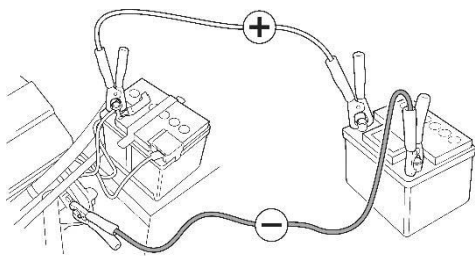

Using jump leads from a donor battery, or a battery fitted to a donor vehicle, is the only approved method of starting a car with a flat battery. Push or tow starting is NOT recommended!

- 1) If a donor vehicle is to be used, the vehicles should be parked with their battery locations adjacent to one another. Ensure that the two vehicles do not touch.
- 2) Apply the handbrakes and ensure that the gear levers on both vehicles are in neutral.
- 3) Turn off the ignition switch and ALL electrical equipment of BOTH vehicles.
- 4) Connect the RED jump lead between the positive (+) terminals of BOTH batteries.
- 5) Connect the BLACK jump lead from the negative (-) terminal of the donor battery, to a good earth point (eg. engine mounting, engine block or other unpainted surface), remote from the battery and well away from fuel and brake lines (see illustrations).

**DO NOT connect a jump lead to the negative (-) terminal of the discharged battery!**

- 6) Check that the cables are clear of the moving parts of both engines, then start the engine of the donor vehicle and allow it to idle for a few minutes.
- 7) Now start the engine of the car with the discharged battery – DO NOT crank the engine for more than 15 seconds at a time.
- 8) Once both engines are running normally, allow them to idle for two minutes, before switching off the engine of the donor vehicle and disconnecting the jump leads. DO NOT switch on any electrical circuits on the previously disabled vehicle, until AFTER the jump leads have been removed.
- 9) Disconnecting the jump leads must be an EXACT reversal of the procedure used to connect them, ie: disconnect the BLACK cable from the earth point on the disabled vehicle FIRST.

### Emergency towing

Both the front and rear towing eyes are intended for use ONLY by the emergency services, or qualified vehicle recovery specialists, to assist in the recovery of your car should a breakdown or an accident occur.

- DO NOT use the lashing eyes to tow your car behind another vehicle.
- DO NOT use the lashing eyes for towing another vehicle.

#### **Towing for recovery**

If your car is to be towed, most qualified recovery specialists will use wheel lift equipment to suspend the front wheels while the rear wheels remain on the ground. However, if it is necessary for the car to be towed with all four wheels on the ground, follow this procedure.

#### **Before being towed:**

- 1) Turn the ignition key to position 'I' to unlock the steering, and then to position 'II' to enable the brake lights, wipers and direction indicators to be operated if necessary.
- 2) Place the gear lever in neutral.
- 3) Release the handbrake.

#### **WARNING!**

- DO NOT attempt to tow the car unless the ignition switch is turned to position 'I', in order to unlock the steering (if, due to an accident or electrical fault, this is considered unsafe, disconnect the battery before turning the switch).
- DO NOT remove the ignition key, or turn the switch to position 'O', while the car is in motion.

## Fuses and relays

The fuse box is located under the dashboard on the vertical face of the engine bulkhead (see illustration below). Although the fuses and relays are not numbered the tables below are in the order that they will be found in the fuse box working from the top down.

**Figure 23: Fuse box and relay location**

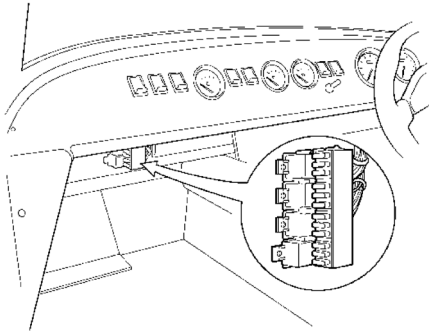

Fuses are simple circuit breakers, which protect electrical equipment by preventing the electrical circuits from being overloaded. A 'blown' fuse is indicated when the electrical equipment it protects becomes inoperative. Check a suspect fuse by removing it from the fuse box and looking for a break in the wire inside the fuse.

### Renewing a fuse

Always turn off the ignition switch and the appropriate electrical circuit before removing a fuse. Always replace a fuse with another of the same (or lower) rating. If a replacement fuse blows almost immediately, this indicates a serious electrical problem and the circuit MUST be checked by Caterham.

### Fuse colours

The fuses are colour coded to identify their amperage ratings as follows:

ORANGE	5 amp
BROWN	7.5 amp
RED	10 amp
BLUE	15 amp
YELLOW	20 amp
CLEAR	25 amp
GREEN	30 amp

## Fuses and relays – 170

**Figure 24: 170 Fuse box and relay layout**

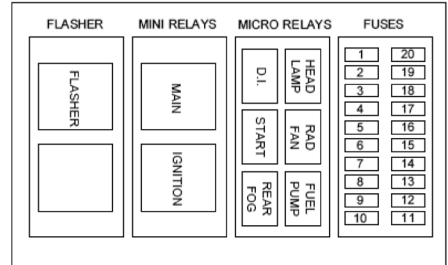

### 160/165/170

#### Fuses

1 = EMS Wake-Up	5A
2 = EMS Ignition Supplies (non-critical)	7.5A
3 = Brake/Reverse Lights	10A
4 = Ignition Services	7.5A
5 = Heater	7.5A
6 = Heated Screen	10A
7 = Wipers / Washer	10A
8 = Power socket	10A
9 = Horns	7.5A
10 = Headlights	15A
11 = Headlight Flash	15A
12 = EMS Ignition Supplies (critical)	15A
13 = Flasher Unit	10A
14 = Diagnostic Connector	5A
15 = Side Lights / Fog Light	7.5A
16 = Immobiliser	7.5A
17 = EMS ECU Power	10A
18 = Not Used	-
19 = Fuel Pump Relay	15A
20 = Cooling Fan Relay	15A

## Fuses and relays – 270/275/280/310/Academy

### 270/310/Academy

#### Relays

Starter	1
Ignition	2
Reverse	3
Flasher Unit	4

#### Fuses

1 = E. C.U/Lambda Ignition Supply	15A
2 = Engine Ignition Supply	15A
3 = Brake/Reverse Lights	11A
4 = Instruments/D.C.M/Relay Drives/ Immobiliser	7.5A
5 = Heater	7.5A
6 = Heated Screen	10A

7 = Wipers/Washer	10A
8 = Power Sockets	10A
9 = Horns	7.5A
10 = Dip Beam/Fog Light	15A
11 = Switch L.E.D./Relay Drives	5A
12 = Side Lights	7.5A
13 = Flasher Unit/D.C.M	10A
14 = E.C.U Main Supply	15A
15 = Main Beam	15A
16 = Immobiliser	7.5A
17 = Cam Sensors	5A
18 = Cam Solenoids	15A
19 = E.C.U Main Supply	20A
20 = E.C.U Main Supply	20A

### 275/280/340

Fuses	
1 = EMS Wake-Up	5A
2 = EMS Ignition Supplies (critical)	15A
3 = Brake/Reverse Lights	10A
4 = Instruments/D.C.M/Relay Drives/ Immobiliser	7.5A
5 = Heater	7.5A
6 = Heated Screen	10A
7 = Wipers/Washer	10A
8 = Power Sockets	10A
9 = Horns	7.5A
10 = Dip Beam/Fog Light	15A
11 = Switch L.E.D./Relay Drives	5A
12 = Side Lights/Fog Light	7.5A
13 = Flasher Unit	10A
14 = Diagnostic Connector	5A
15 = Main Beam	15A
16 = Immobiliser	7.5A
17 = Main Relay	15A
18 = EMS Ignition Supplies (non-critical)	7.5A
19 = Fuel Pump Relay	15A
20 = Cooling Fan Relay	15A

J = Power Sockets	10A
K = Horns	7.5
L = Dip Beam/Fog Light	15A
M = Switch LED'S	10A
N = Side Lights	7.5A
O = Flasher Unit / D.C.M	10A
P = P.C.M Main Supply	15A
Q = Main Beam	15A
R = Immobiliser/Ignition & Starter Relays	5A

Note: \* 620 uses 30A

### 480/485

Relays	
Starter	1
Ignition	2
Reverse	3
Flasher	4
Fuses	
1 = E.M.S Ignition Supplies	15A
2 = Engine Ignition Supply	15A
3 = Brake/Reverse Lights	10A
4 = Instruments/D.C.M/Relay Drives/ Immobiliser	7.5A
5 = Heater	7.5A
6 = Demist	10A
7 = Wipers/Washer	10A
8 = Power Sockets	10A
9 = Horns	7.5A
10 = Dip Beam/Fog Light	15A
11 = Switch L.E.D./Relay Drives	5A
12 = Side Lights	7.5A
13 = Flasher Unit/D.C.M	10A
14 = Diagnostic Connector	5A
15 = Main Beam	15A
16 = Immobiliser	7.5A
17 = Main Relay	15A
18 = Cooling Fan Relay 1	30A
19 = Fuel Pump Relay	15A
20 = Cooling Fan Relay 2	15A

### Fuses and relays – 360/420/480/485/620

#### 360/420/620

Relays	
Cooling Fan	1
Fuel Pump	2
Starter	3
Ignition	4
Flasher Unit	5
Reverse Light	6
Fuses	
A = P.C.M Ignition Supply	15A
B = Engine Ignition Supply	15A
C = Cooling Fan	20A*
D = Fuel Pump	15A
E = Brake / Reverse Lights	10A
F = Instruments/D.C.M/Heated Seats	20A
G = Heater	7.5A
H = Heated Screen	10
I = Wipers/Washer	10A

Figure 25: 360/420/480/485/620

#### Fuse Box and Relay layout

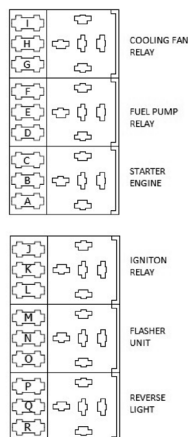

## Parts & Accessories

### Service parts & accessories

Only Caterham Cars and their approved dealers are able to provide the full range of recommended parts and accessories which meet our rigorous standards of safety, durability and performance.

To ensure your future driving pleasure and safety, we strongly recommend that only Caterham approved parts are fitted to your car.

All genuine Caterham parts and accessories are guaranteed for twelve months or 6000 miles (whichever is sooner).

A comprehensive parts resource is available from Caterham Aftersales or via our online store at [www.caterhamcars.com](http://www.caterhamcars.com)

Fitting of non-Caterham approved parts may affect the resale value of your car.

### WARNING!

- *It is extremely hazardous to fit parts or accessories where installation requires the dismantling of, or addition to, either the electrical or fuel systems.*
- *Fitting parts or accessories that have not been approved by Caterham, or the carrying out of non-approved alterations or conversions, may be dangerous and could affect the safety of the car and occupants, and also invalidate the terms and conditions of the car's warranty.*

## Bulb Replacement

### Bulb replacement part numbers from Caterham

Light Unit	Wattage	Caterham Part Number
Headlamp (halogen)	60/55	BB472
Sidelamp	5	LLB501
Front/Rear Indicator	21	LLB382
Tail/Stop	21/5	LLB380
Rear Fog	21	LLB382
Side Repeater Indicator	4	LLB233
Reversing	21	LLB382
Rear Number Plate (x2)	4	LLB233

## Headlamps

Loosen the screw on top of the headlamp bowl until the rim with the light attached can be unclipped and pulled free. The wiring is released from the back of the lamp unit by pulling off the plastic connection. The bulbs can be changed by removing the rubber dust cover then squeezing the retaining clip to release the bulb itself. Care should be taken not to touch the Halogen bulb glass as this may cause it to blow on first use.

### Side lamp (front)

First release headlamps as above. Sidelamps are connected separately into the back of the headlamp and pull free to enable bulb changing. The side lamp bulb is a capless bulb and can be removed by pulling it straight out of its holder.

### Indicators (front)

Remove the two screws holding the lens in place. The bulb can then be removed and the new one refitted by pushing and turning through 45°.

### Indicator repeaters (front)

Remove the single screw holding the lens and unclip. The bulb can then be removed and the new one refitted by pushing and turning through 45°.

### Stop/tail and indicators (rear)

The lenses are held in place by two screws which allow the complete lens to be removed for access. The bulbs can then be removed and the new ones refitted by pushing and turning through 45°.

### Rear fog light, reversing light

The lenses are held in place by two screws which allow the lens to be removed for access. The bulbs can then be removed and the new ones refitted by pushing and turning through 45°. When refitting the lens ensure that the rubber seal is fitted correctly to prevent water ingress.

### Number plate lamp

The number plate lamp contains two bulbs which can be removed and refitted by pushing and turning through 45°. To gain access to the bulbs the black cover must be removed, this is held in place by a single screw in the centre of the cover.

## Torque Figures

Location	Washers	Torque Nm
Lower wishbone front	Spring and plain	81
Lower wishbone rear	Plain spacers	81
Upper wishbone front	None	47
Upper wishbone rear	None	47
Front spring damper top	Spring and plain	20
Front spring damper bottom	Loctite	20
Upright to top ball joint	None	54
Upright to lower wishbone spherical	Spacer (widetrack only)	54
Front anti-roll bar clamps	None	20
Steering rack clamps	Plain under bolt head	11
Steering column universal joint	None	20
Steering column clamp plate	Spring and plain under bolt head	14
Track rod end to upright	None	41
Differential mounting upper (BMW)	Plain under bolt head and nut	54
Differential mounting lower (BMW)	Plain under bolt head	81
Differential mounting upper (Sierra)	Plain under bolt head	54
Differential mounting lower (Sierra)	Plain under bolt head	54
Propshaft	None	60
Propshaft (Suzuki)	None	23
Rear spring damper top	None	47
Rear spring damper bottom (Suzuki)	Spring and plain	70
Watts link locknut	None	20
Bellcrank to link	None	14
Watts link rear mount		34
Watts link front mount		34
Bellcrank to De Dion		34
Radius arm front		47
Radius arm rear		81
'A' frame	None	81
Hub nuts rear	Thrust	270
Brake calliper	Plain and spring	47
Rear anti-roll bar clamp	Plain under bolt head and spring under nut	7

## Torque Figures continued



Location	Washers	Torque Nm
De Dion ears	Plain and spring	47
Gearbox to bell-housing	Spring under bolt head	68
Gearbox mount	Spring under bolt head	61
Stub axle to wingstay		81
Brake caliper		25
Brake caliper to carrier		47
Engine to bell-housing	Spring under bolt head	47
Bell-housing to sump	None	20
Starter motor	Spring under bolt head	54
Engine mounting bracket (M10)	Spring under bolt head	35
Engine mounting bracket (M8)	Spring under bolt head	20
Engine mounting bracket (M6)		12
Engine mounting bracket to mounting rubber		81
Engine mounting to rubbers	Spring under bolt head	34
Gearbox mount to chassis	Plain between chassis and nut	20
Exhaust manifold	None	47
Expansion tank bracket	Plain under bolt head and nut	10
Gearlever to tail-housing	None	20
Brake banjo bolt	Copper washer each side of banjo	10
Brake unions	None	10
Seat belt / harness bolts		47
Schroth harness bolts		41
All roll over bar fixings		M8 25 / M10 47
Wheel nuts (2 part nut and tapered washer)	Tapered	85



# CATERHAM

Caterham Cars Limited, Unit 10 Rennie Dr, Dartford DA1 5FD

[caterham.com](https://www.caterham.com)

 /CaterhamCars  @caterhamcars  caterhamcarsltd

© Caterham 2024

Content is subject to change without notice. Images are for illustrative purposes only.

Printed in the UK. Service Book Edition 1.4 05/24